

Look B: Custom Build

To choose from our full suite of colors and additional baluster options, go custom.

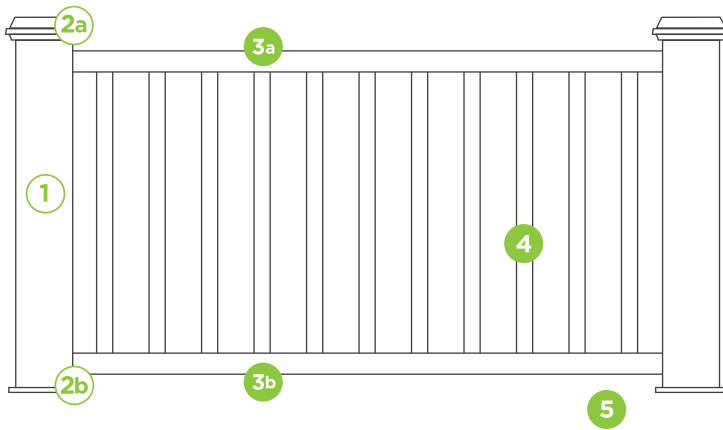

- 1 POST SLEEVE
- 2a POST SLEEVE CAP
- 2b POST SLEEVE SKIRT
- 3a TOP RAIL
- 3b BOTTOM RAIL
- 4 INFILL
- 5 ACCESSORY INFILL KIT

3a

CROWN TOP RAIL

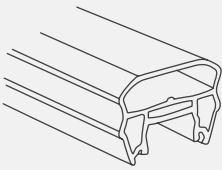

UNIVERSAL TOP/BOTTOM RAIL

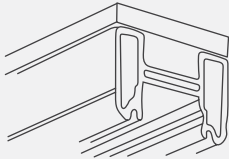

4

ROUND ALUMINUM BALUSTERS



SQUARE ALUMINUM BALUSTERS



SQUARE COMPOSITE BALUSTERS



3b

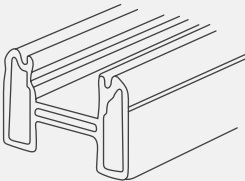

UNIVERSAL TOP/BOTTOM RAIL

5

ACCESSORY INFILL KIT



CUSTOM COLORS:



Composite

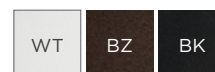

Aluminum

Look A: Rail Kit

Available in our most popular composite hues, a Transcend kit simplifies decision making.

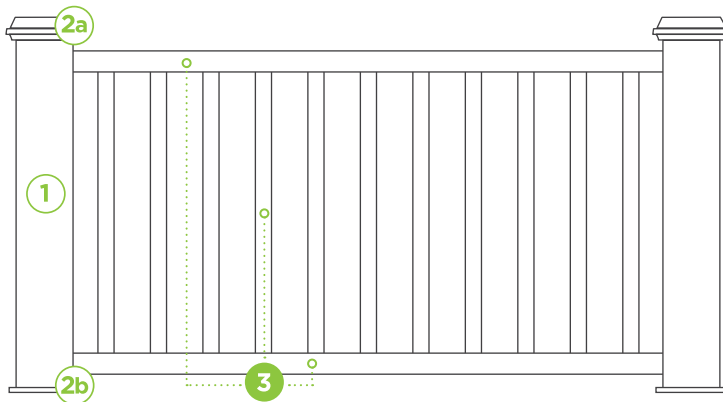

- 1** POST SLEEVE
- 2a** POST SLEEVE CAP
- 2b** POST SLEEVE SKIRT
- 3** RAIL KIT: TOP RAIL, BOTTOM RAIL, INFILL

3 RAIL & BALUSTER KIT

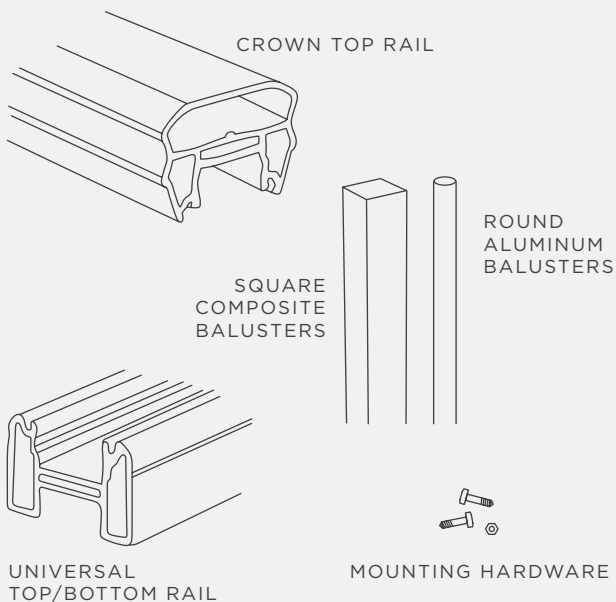

3 COCKTAIL RAIL & BALUSTER KIT

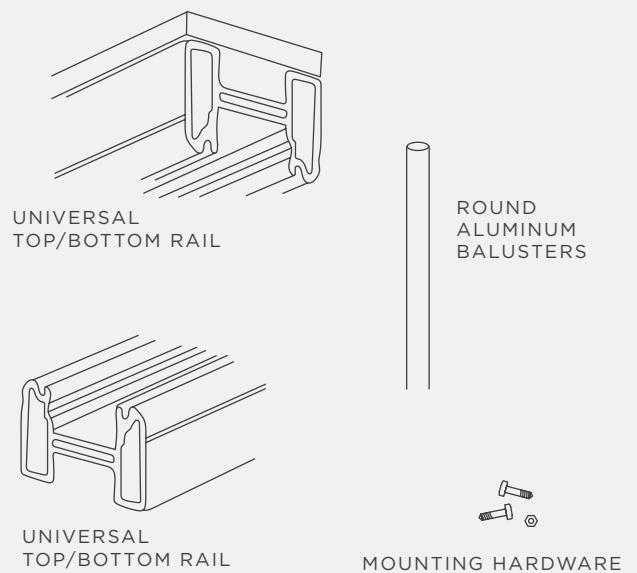

RAIL & BALUSTER
KIT COLORS:



Composite

Aluminum

COCKTAIL RAIL &
BALUSTER KIT COLORS:



Composite

Aluminum

Product Options

STEPS 1, 2A, 2B: PICK A POST STYLE

1

POST SLEEVE

Each 4" x 4" and 6" x 6" post sleeve fits over a 4" x 4" pressure treated post or equivalent post mount. 6" x 6" width only available in Classic White.



Heights
39", 108"

Widths
4" x 4", 6" x 6"



2a

POST SLEEVE CAP

6" x 6" width only available in Classic White.



Profiles
Flat, Pyramid

Widths
4" x 4", 6" x 6"



Opt for post cap light variations, available in both flat and pyramid profiles. Details on page 60.

2b

POST SLEEVE SKIRT

6" x 6" width only available in Classic White.



Widths
4" x 4", 6" x 6"



STEP 3A: PICK A TOP RAIL

3a CROWN TOP RAIL



Lengths

6', 8'
(67.5", 91.5")



3a UNIVERSAL TOP/BOTTOM RAIL

Use for cocktail rail applications.



Lengths

6', 8'
(67.5", 91.5")



STEP 3B: PICK A BOTTOM RAIL

3b UNIVERSAL TOP/BOTTOM RAIL



Lengths

6', 8'
(67.5", 91.5")



STEP 4: CHOOSE AN INFILL

4

SQUARE COMPOSITE BALUSTERS

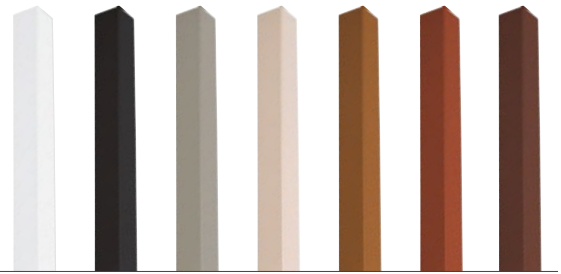

Heights
36", 42"



4

ROUND ALUMINUM BALUSTERS



Heights
36", 42"



4

SQUARE ALUMINUM BALUSTERS



Heights
36", 42"



4

GLASS INFILL PANEL

Glass infill not sold by Trex.

To complete your rail section, see specifications below.

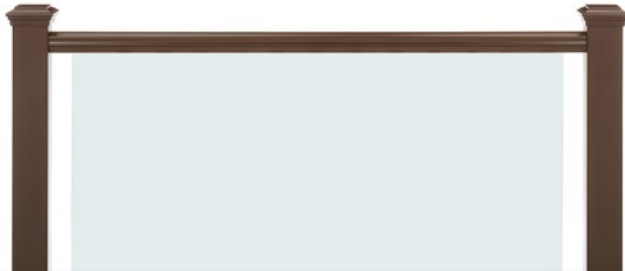

GLASS INFILL PANEL SPECIFICATIONS:

Source 1/4" tempered glass infill by contacting your local glass supplier or call 1-800-BUY-TREX for more information.

Additional Specs

- 1/4" x 30" x 63 1/2" max. (6 mm x 762 mm x 1613 mm)
- 1/4" x 36" x 63 1/2" max. (6 mm x 914 mm x 1613 mm)

STEP 5: SELECT AN ACCESSORY INFILL KIT

5

SQUARE COMPOSITE BALUSTER INFILL KIT

Use this hardware to assemble a railing section consisting of square composite balusters.



Lengths

6', 8'

Applications

Horizontal, Stair



5

ROUND ALUMINUM BALUSTER INFILL KIT

Use this hardware to assemble a railing section consisting of round aluminum balusters.



Lengths
6', 8'

Applications
Horizontal, Stair



5

SQUARE ALUMINUM BALUSTER INFILL KIT

Use this hardware to assemble a railing section consisting of square aluminum balusters.



Lengths
6', 8'

Applications
Horizontal, Stair



5

GLASS PANEL INFILL KIT

Use this hardware to assemble a Transcend railing section with a glass infill.

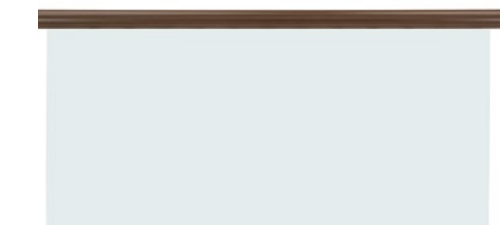

Lengths
6'

