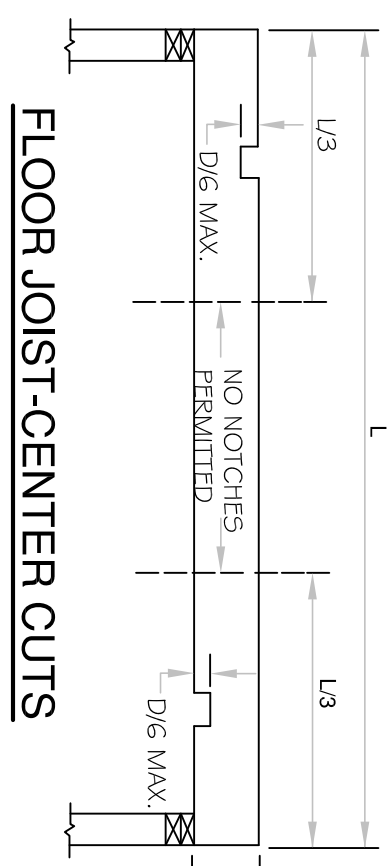
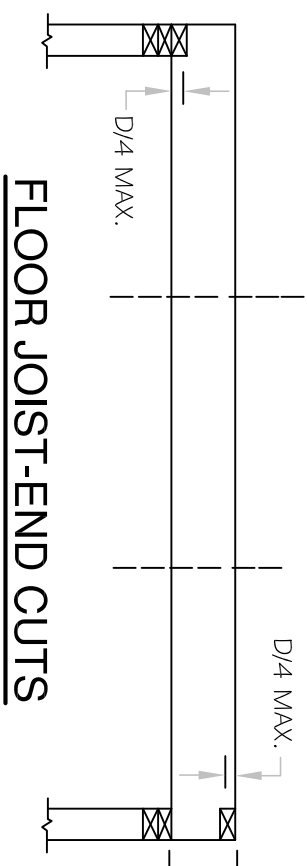

**FIGURE R602.6.1**  
**TOP PLATE FRAMING TO ACCOMMODATE PIPING**



**FLOOR JOIST-CENTER CUTS**



**FLOOR JOIST-END CUTS**

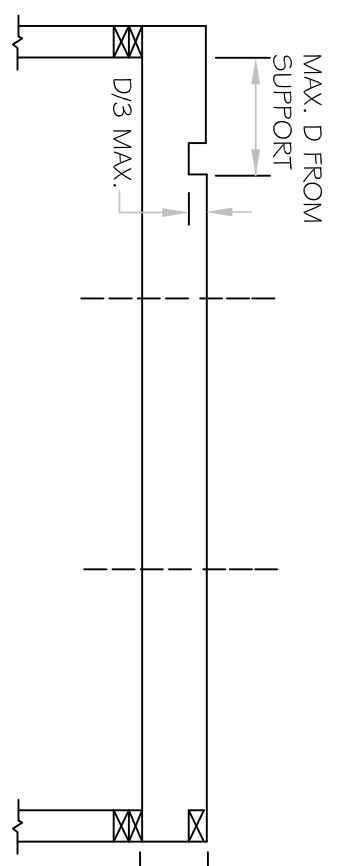

**RAFTERS/CEILING JOISTS (R602.6)**

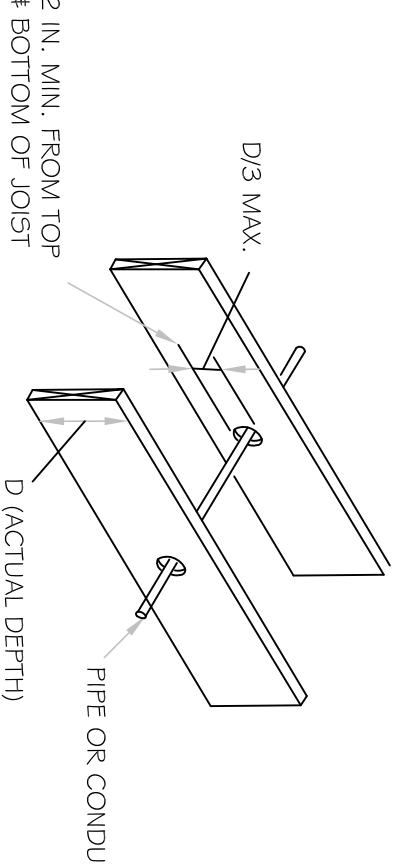

**FIGURE R502.8**  
**CUTTING, NOTCHING & DRILLING**

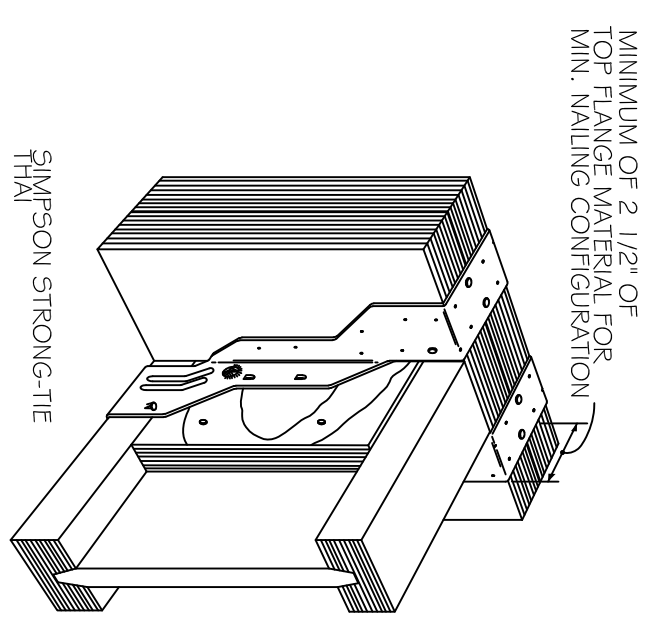

**FLUSH CONNECTION DETAIL**  
NOT TO SCALE

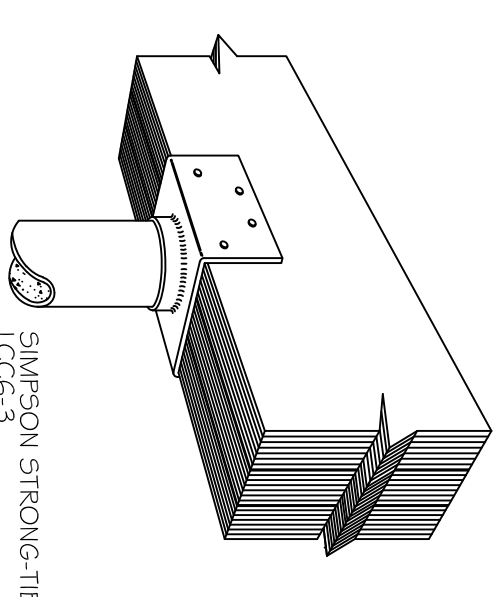

**LALLY COLUMN DETAIL**  
NOT TO SCALE

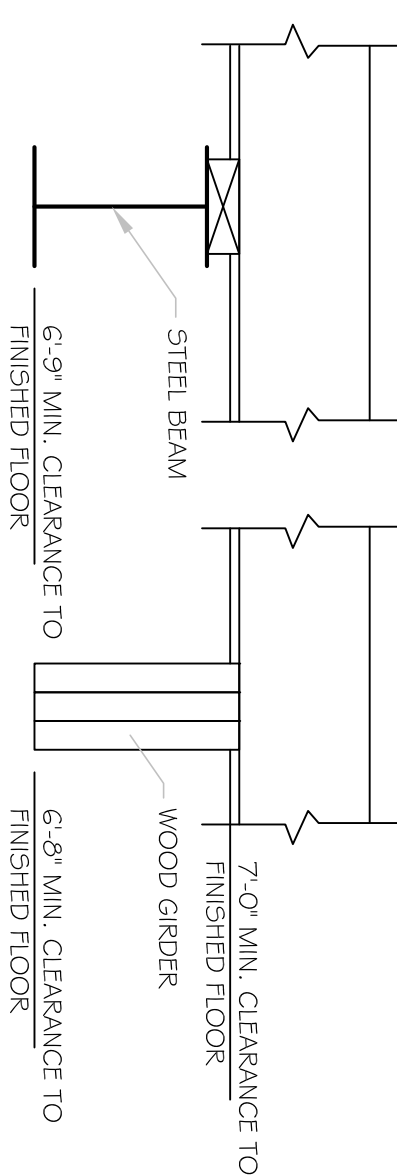

**TYPICAL GIRDER CLEARANCE DETAIL**  
SCALE: NOT TO SCALE

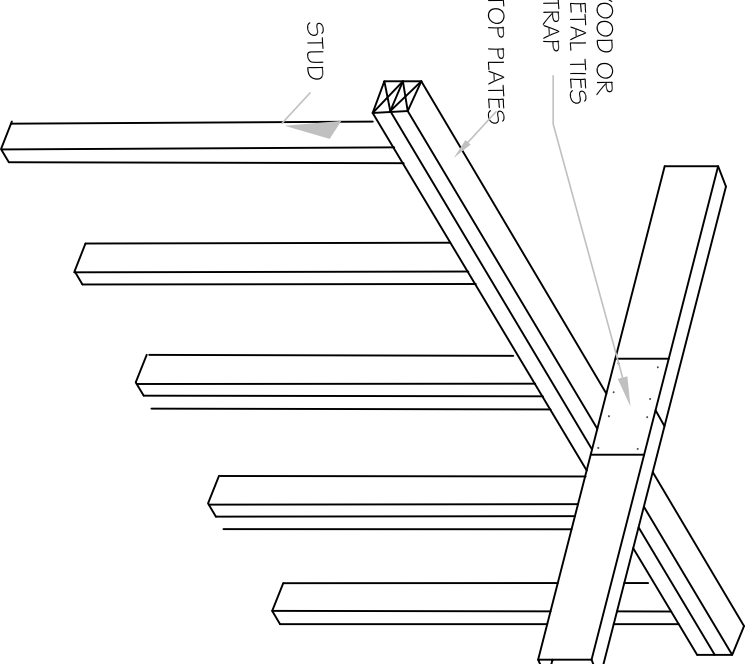

**FIGURE R802.3.2(2)**  
**BUTTED CEILING JOIST CONNECTION**

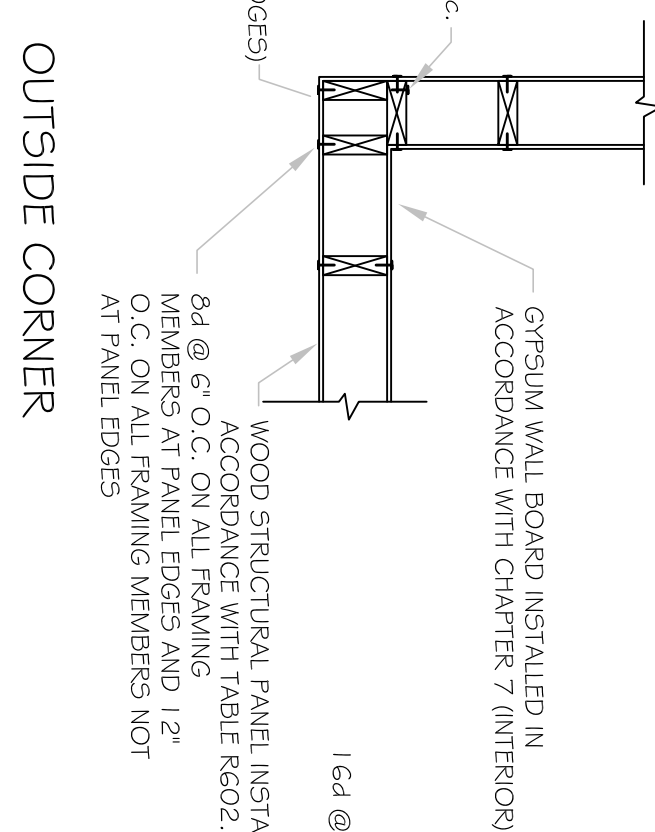

**OUTSIDE CORNER EXTERIOR CORNER FRAMING DETAIL**  
NOT TO SCALE

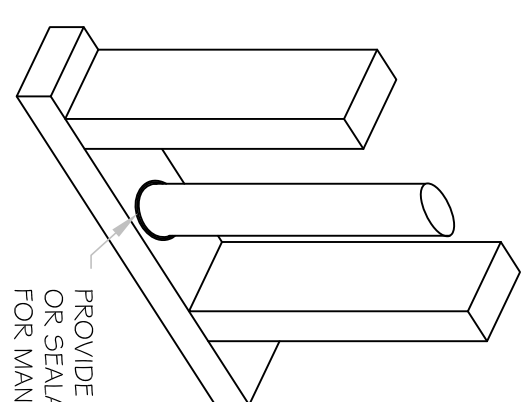

**FIRESTOPPING @ PIPE PENETRATION**  
NOT TO SCALE

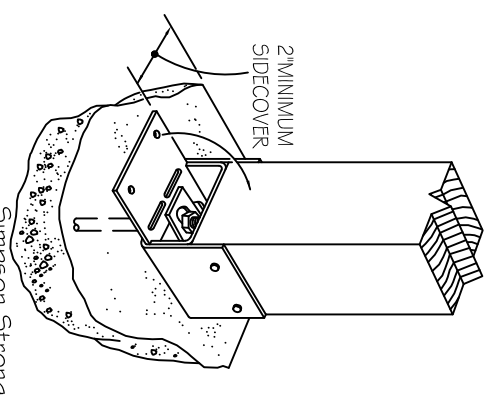

**DECK BASE CONNECTION DETAIL**  
NOT TO SCALE

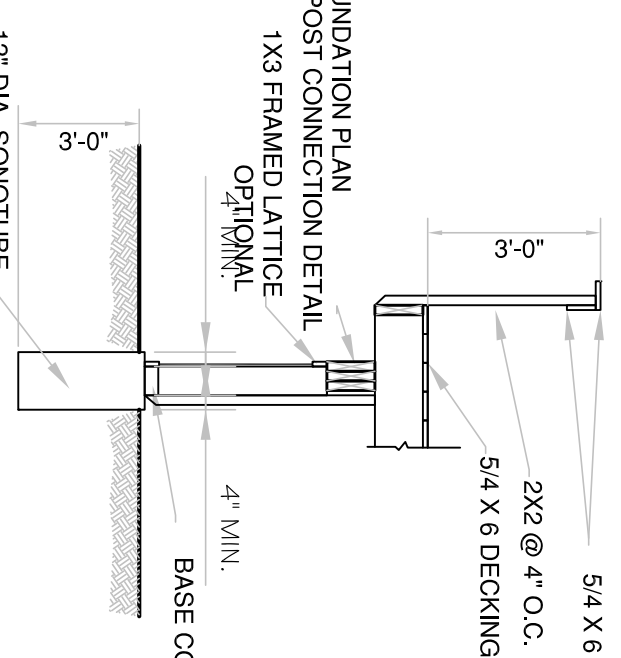

**FIGURE R602.6(1)**  
**NOTCHING & BORING HOLE LIMITATIONS FOR EXTERIOR WALLS & BEARING WALLS**

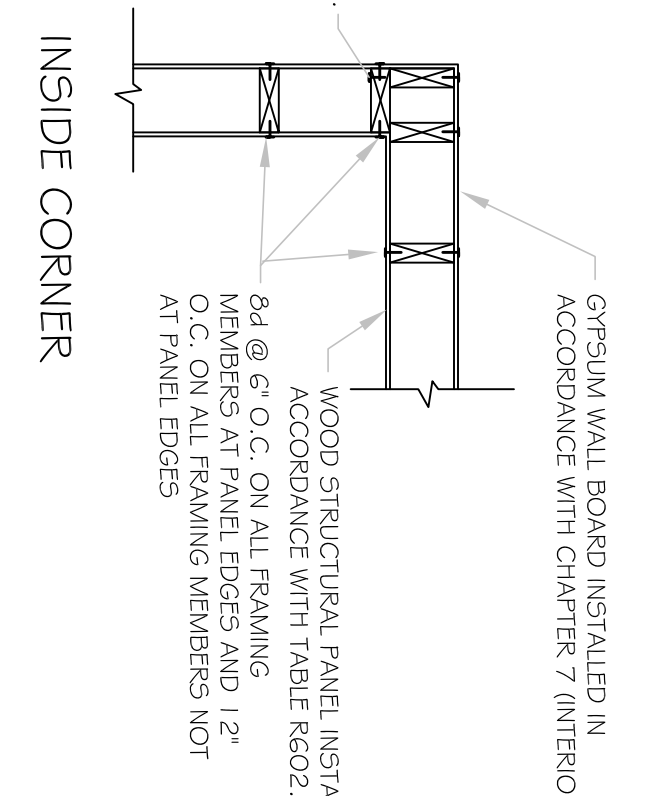

**INSIDE CORNER EXTERIOR CORNER FRAMING DETAIL**  
NOT TO SCALE

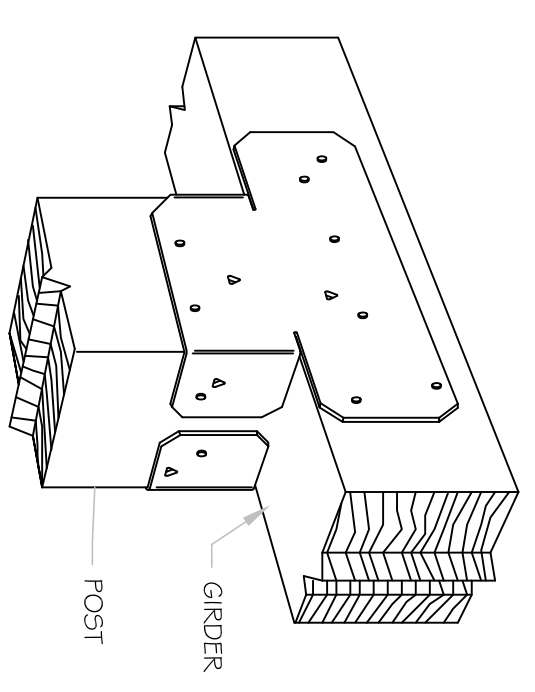

**DECK POST CONNECTION DETAIL**  
NOT TO SCALE

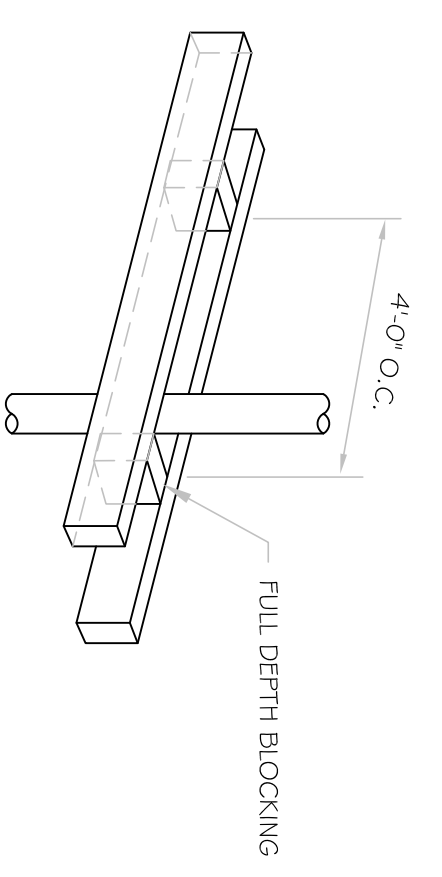

**BLOCKING FOR PENETRATION @ BEARING PARTITION**  
NOT TO SCALE

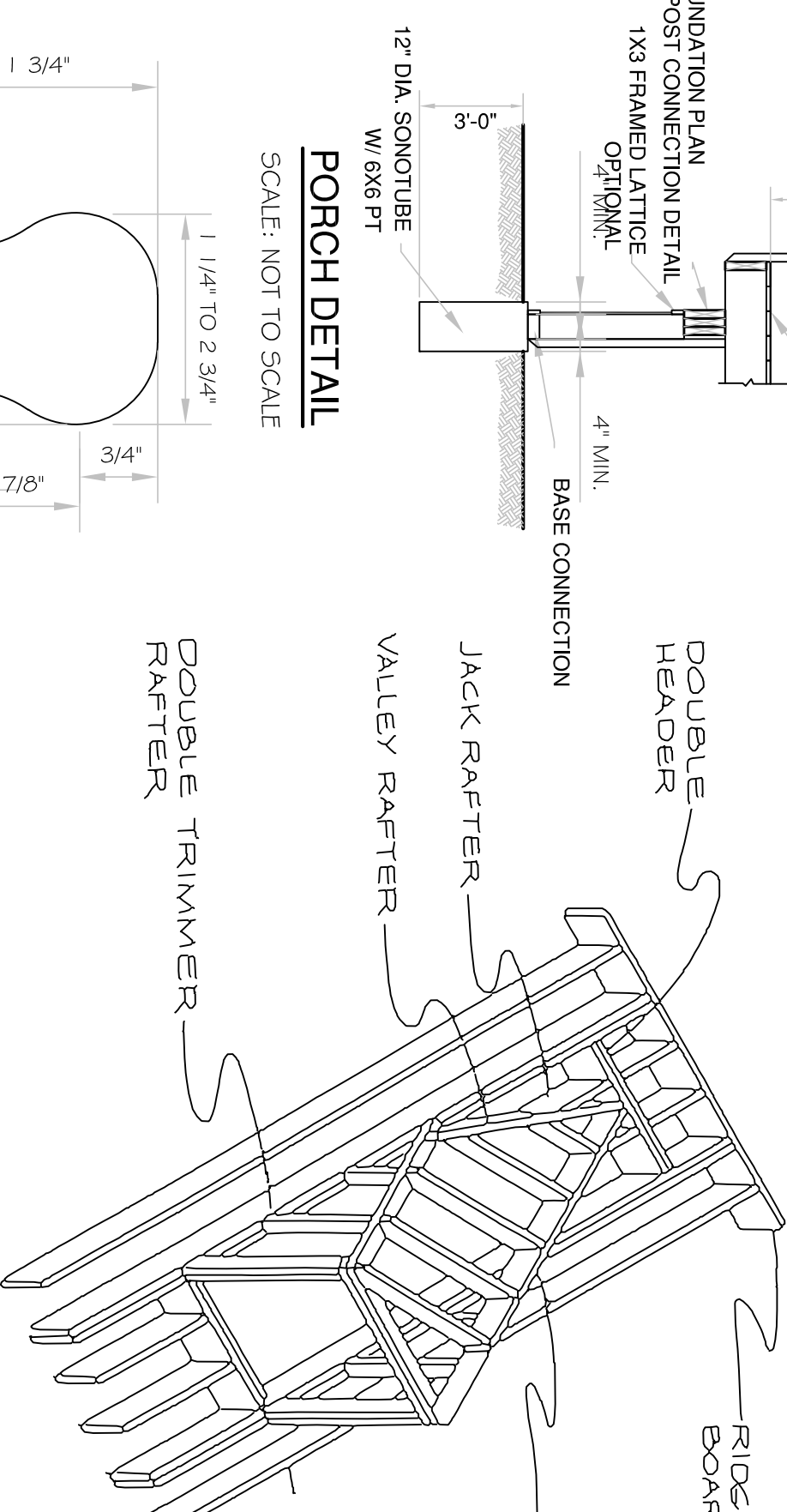

**FIGURE R602.6(1)**  
**NOTCHING & BORING HOLE LIMITATIONS FOR EXTERIOR WALLS & BEARING WALLS**

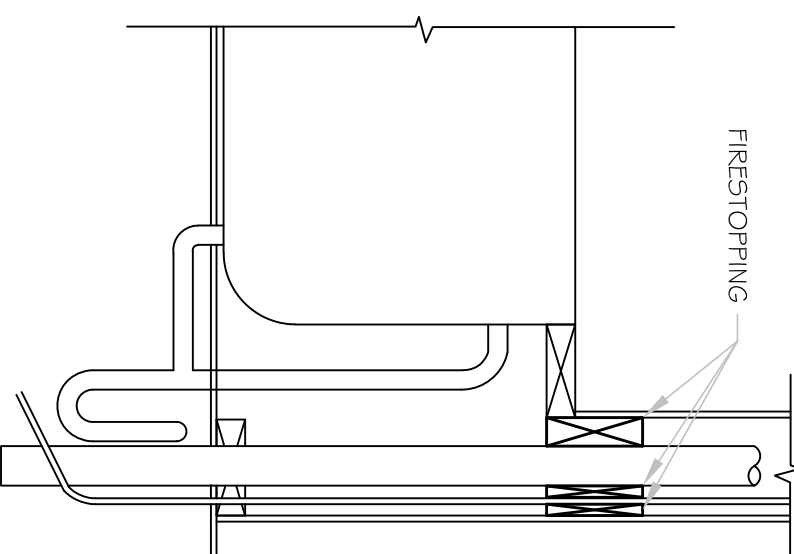

**FIGURE R602.6(2)**  
**NOTCHING & BORING HOLE LIMITATIONS FOR INTERIOR NONBEARING WALLS**

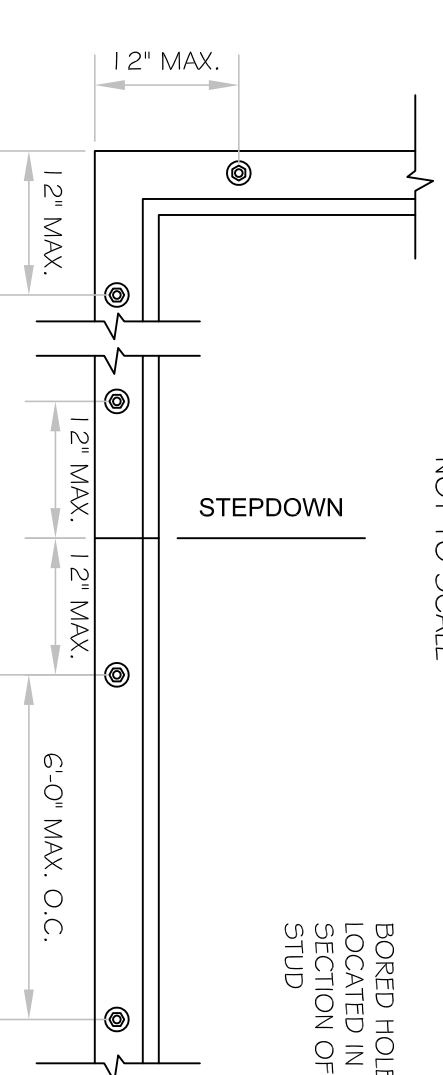

**WOOD SILL PLATE ANCHORAGE DETAIL**  
NOT TO SCALE

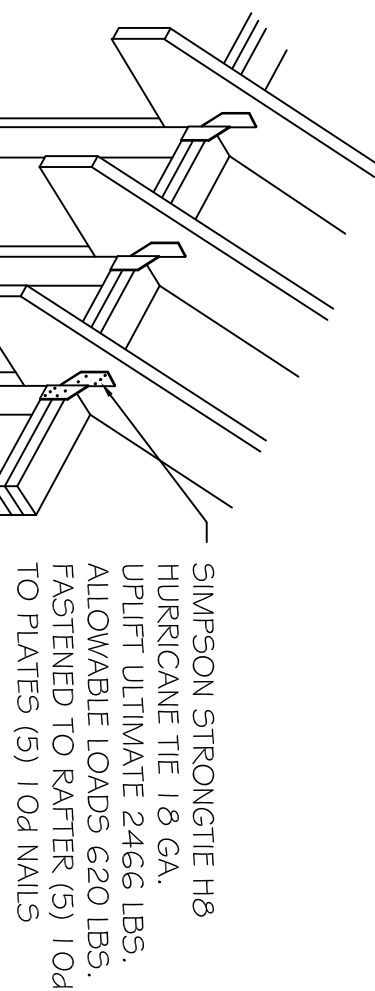

**HURRICANE UPLIFT TIES**

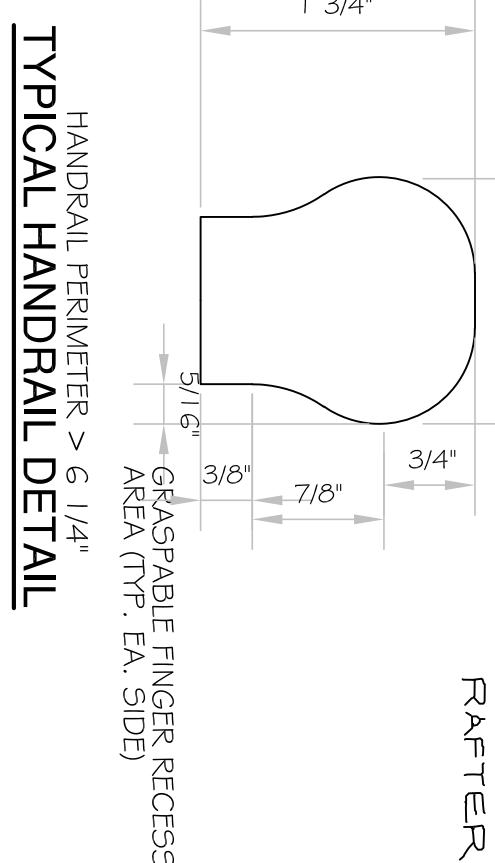

**TYPICAL HANDRAIL DETAIL**  
SCALE: NOT TO SCALE

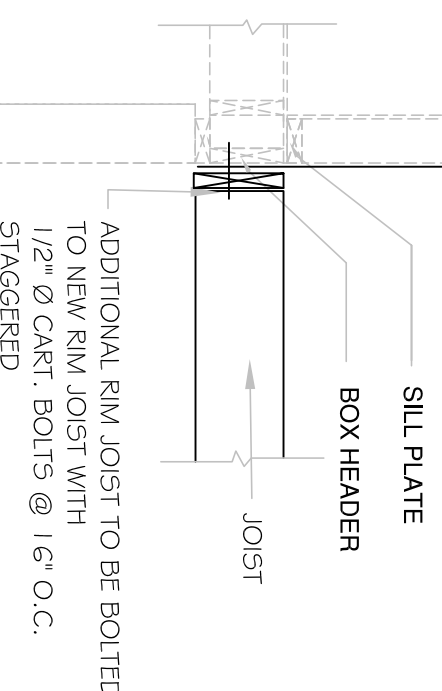

**CONNECTION DETAIL**  
SCALE: NOT TO SCALE

**DETAILS & SPECIFICATIONS**

FOR  
606 PALMER LANE  
TAX LOT 6005-2-34  
**ALMETTA J**

LOCATED IN THE  
VILLAGE OF UPPER NYACK  
TOWN OF CLARKSTOWN  
ROCKLAND COUNTY, NEW YORK

**PAUL CDANSMAN, PE, PLLC**  
25 RIVERSIDE DRIVE  
SUFFERN, N.Y. 10901  
TEL: (917) 418-0999  
EMAIL: PCDSKI@EARTHLINK.NET

DWG #	SCALE	DATE	FILE #
3 OF 3	AS SHOWN	JAN. 31, 2020	606PAL