

SITE PLAN

SCALE: 1" = 20'

Slope Percentage	Existing Area (SF, +/-)	Proposed Area (SF, +/-)	Net Change (SF, +/-)
0 - 10%	38,794	38,719	(75)
10 - 20%	11,778	11,898	120
20 - 30%	5,384	5,355	(29)
30 - 40%	1,766	1,750	(16)
40 - 50%	806	806	-
50 - 100%	2,338	2,338	-
Area from structures	10,821	10,821	-
Total	71,687	71,687	-

SLOPE ANALYSIS SUMMARY

	Requirements	Existing Conditions	Proposed Conditions	Requested Variances
19.1 Table of Lot Areas and Restrictions in Residence Districts - R-2				
Minimum lot area required (SF +/-)	30,000	71,687	71,687	None
Minimum front footage on streets (ft. +/-)	100	124	124	None
Minimum setback from front street line (ft. +/-)	35	129	129	None
Minimum setback from side and rear lot lines (ft. +/-)	25	25	25	None
19.2 Table of Residence and Dwelling Dimensions - R-2				
Minimum livable floor area single floor dwelling (SF +/-)	1,250	N/A	N/A	None
Minimum livable floor area two (2) floor dwellings - First floor (SF +/-)	800	4,854	4,854	None
Minimum livable floor area two (2) floor dwellings - Second floor (SF +/-)	750	N/A	N/A	None
Maximum structure height (ft. +/-)	35	N/A	N/A	None
Maximum coverage of lot by buildings and structures (%)	25%	15.1%	15.1%	None
Maximum coverage of lot by primary building (%)	12%	6.8%	6.8%	None

BULK TABLE

NOTES:

1. THE PROPOSED SEAWALL WORK IS REPLACEMENT IN KIND.
2. OWNER OF RECORD: 517 NORTH BROADWAY, LLC, 517 NORTH BROADWAY, UPPER NYACK, NY 10960.
3. NAME AND ADDRESS OF SURVEYOR OF RECORD: CONTROL POINT ASSOCIATES INC. PC, 17 COMPUTER DRIVE WEST, ALBANY, NY 12205. SURVEY WAS COMPLETED ON OCTOBER 17, 2019.
4. ZONING DISTRICT: R-2
5. THERE ARE NO NEW PROPOSED STRUCTURES WITHIN SITE PERIMETER.
6. APPROVED SITE PLAN IS VALID FOR 3 YEARS FOLLOWING APPROVAL BY VILLAGE OF UPPER NYACK.
7. APPLICABLE CONSTRUCTION AND UTILITY STANDARDS WILL BE ADHERED TO FOR THE PROPOSED WORK.
8. NO HIGHWAY TREE PLANTING IS NEEDED FOR THE PROPOSED WORK.
9. NO DISTURBANCE TO EXISTING UTILITIES WILL OCCUR FROM THIS WORK.
10. NO RESTRICTIVE COVENANTS APPLY TO THIS PROPERTY.
11. ELEVATIONS SHOWN ARE IN REFERENCE TO NAVD88.
12. PROPOSED PIER AND DOCK STRUCTURES IN HUDSON RIVER ARE DESIGNED BY BUCKMAN ENGINEERING, PLLC AND REFERENCED IN THE DESIGN DRAWINGS "SEAWALL REHABILITATION AND DOCK WORK " DATED DECEMBER 3, 2020, REV 01, MAY 26, 2021.
13. TRUNK CALIPER FOR NEW TREES SHALL MEET ANSI Z60 CURRENT EDITION FOR ROOT BALL SIZE. BOTTOM OF ROOT BALL TO REST ON COMPACTED SOIL. PRIOR TO MULCHING, LIGHTLY TAMP SOIL AROUND ROOT BALL IN 6" LIFTS TO BRACE TREE. DO NOT OVER COMPACT. WHEN PLANTING HOLE HAS BEEN BACKFILLED, POUR WATER AROUND THE ROOT BALL TO SETTLE THE SOIL.
14. TREES SHALL BE ONE TYPE ONE SHADE & FLOWERING TREE, AND TWO TYPE TWO SHADE TREES.

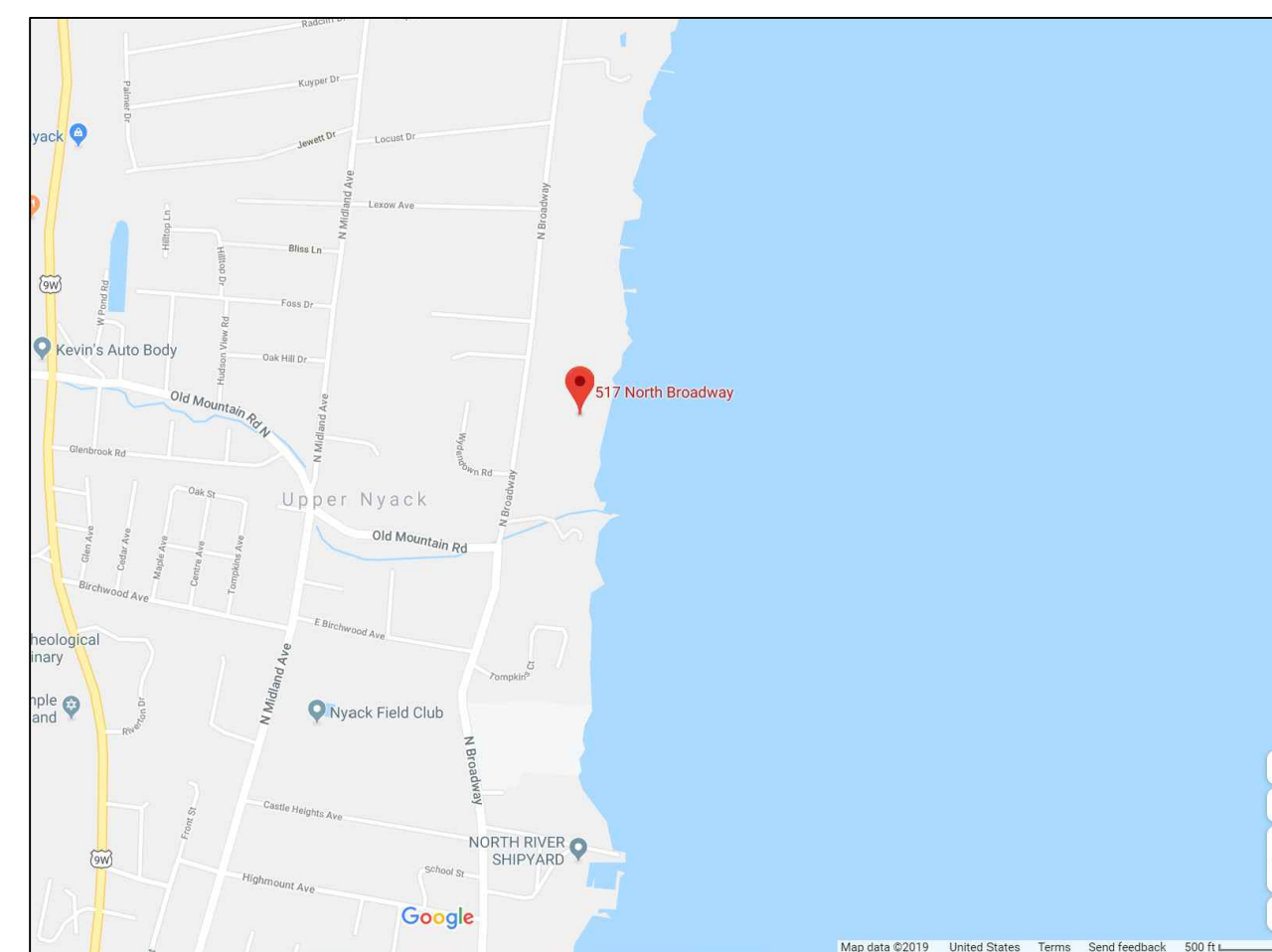

VICINITY MAP (SOURCE: GOOGLE MAPS)

DRAWING LIST:

SHEET	DRAWING	DRAWING TITLE	REVISION
1	C-100	SITE PLAN	5-26-21
2	N/A	TOPO AND HYDRO SURVEY, CPA	11-5-19
3	N/A	TITLE SURVEY WEJA	3-19-21
4	T-01	[MARINE] TITLE SHEET	5-26-21
5	G-01	[MARINE] GENERAL NOTES	5-26-21
6	MR-01	[MARINE] EXISTING PLAN	4-01-21
7	MR-02	[MARINE] PROPOSED PLAN	4-01-21
8	MR-03	[MARINE] PIER AND DOCK PLAN	4-01-21
9	MR-04	[MARINE] PIER AND DOCK ELEVATIONS	5-26-21
10	MR-05	[MARINE] PIER DETAILS 1	5-26-21
11	MR-06	[MARINE] PIER DETAILS 2	5-26-21
12	MR-07	[MARINE] PIER DETAILS 3	5-26-21
13	MR-08	[MARINE] GANGWAY DETAILS	4-01-21
14	MR-09	[MARINE] FLOATING DOCK DETAILS	5-26-21
15	MR-10	[MARINE] MISCELLANEOUS DETAILS	5-26-21

517 North Broadway

517 NORTH BROADWAY
UPPER NYACK, NY 10960

CLIENT

517 NORTH BROADWAY, LLC

517 NORTH BROADWAY
UPPER NYACK, NY 1960

PRIME CONSULTANT



TMS WATERFRONT
247 WEST 35TH ST. 10 NORTH
NEW YORK, NY 10001
+1.917.246.6788

REV	DATE	ISSUE
02	MAY 26 2021	VILLAGE COMMENTS
01	FEB 25 2021	VILLAGE APPROVAL
00	FEB 10 2021	VILLAGE APPROVAL

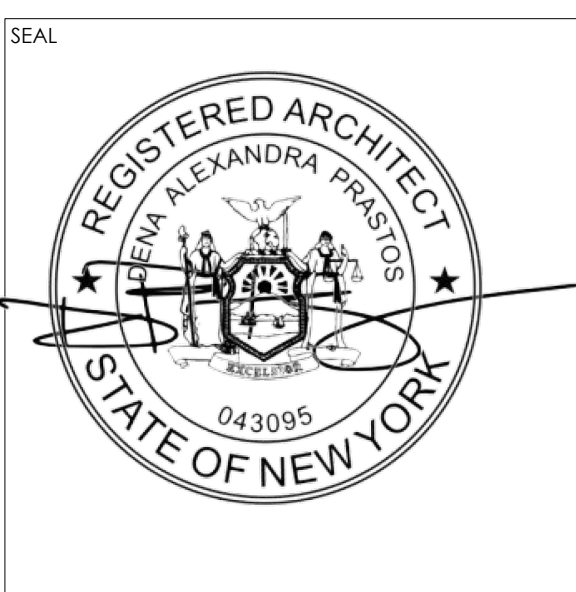

SHEET NAME

SITE PLAN

DATE: FEB 10, 2021 DRAWN BY: EGB CHECKED BY: DAP

FORMAT: ANSI B SCALE: 1" = 20'

SHEET NO. C-100

1 OF 1

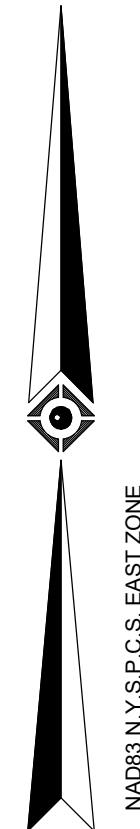

VICINITY MAP
© 2008 Delorme Aeronet Atlas USA

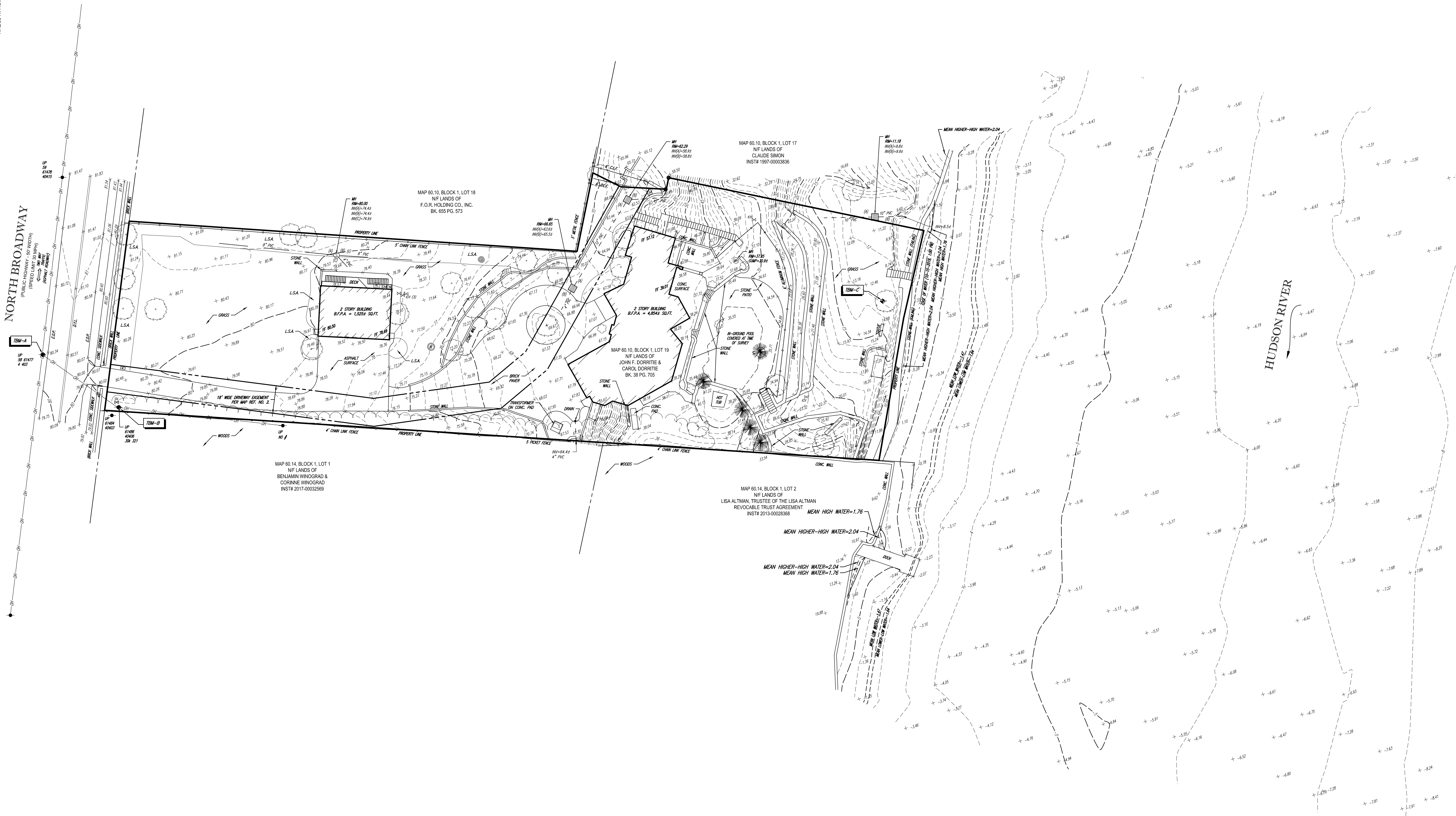

- NOTES:**
- PROPERTY KNOWN AS LOT 19, BLOCK 1 AS SHOWN ON THE OFFICIAL TAX MAP OF THE VILLAGE OF UPPER NYACK, ROCKLAND COUNTY, NEW YORK TAX MAP NO. 66.10.
 - AREA = 71,687.2 SQ. FT. OR 1.6464 ACRES
 - LOCATION OF UNDERGROUND UTILITIES ARE APPROXIMATE. LOCATIONS AND SIZES ARE BASED ON UTILITY MARK-OUTS, ABOVE GROUND STRUCTURES THAT WERE VISIBLE & ACCESSIBLE IN THE FIELD, AND THE MAPS AS LISTED IN THE REFERENCES AVAILABLE AT THE TIME OF THE SURVEY. AVAILABLE AS-BUILT PLANS AND UTILITY MARK-OUT DOES NOT ENSURE MAPPING OF ALL UNDERGROUND UTILITIES AND STRUCTURES. BEFORE ANY EXCAVATION IS TO BEGIN, ALL UNDERGROUND UTILITIES SHOULD BE VERIFIED AS TO THEIR LOCATION, SIZE AND TYPE BY THE PROPER UTILITY COMPANIES. CONTROL POINT ASSOCIATES, INC. DOES NOT GUARANTEE THE UTILITIES SHOWN COMPRISE ALL SUCH UTILITIES IN THE AREA EITHER IN SERVICE OR ABANDONED.
 - THIS PLAN IS BASED ON INFORMATION PROVIDED, BY A SURVEY PREPARED IN THE FIELD BY CONTROL POINT ASSOCIATES, INC. AND OTHER REFERENCE MATERIAL, AS LISTED HEREON.
 - PROPERTY LINES SHOWN BASED ON MAP REFERENCE NO. 2. A BOUNDARY SURVEY WAS NOT PERFORMED BY CPA IN CONJUNCTION WITH THE PREPARATION OF THIS PLAN. THIS SURVEY WAS PREPARED WITHOUT THE BENEFIT OF A TITLE REPORT AND IS SUBJECT TO THE RESTRICTIONS, COVENANTS AND/OR EASEMENTS THAT MAY BE CONTAINED THEREIN.
 - THE EXISTENCE OF UNDERGROUND STORAGE TANKS, IF ANY, WAS NOT KNOWN AT THE TIME OF THE FIELD SURVEY.
 - OBSERVATIONS REFER TO THE NORTH AMERICAN VERTICAL DATUM OF 1988 (NAV88), BASED ON GPS OBSERVATIONS TAKEN AT THE TIME OF THE SURVEY.
TEMPORARY BENCH MARKS SET:
TBM-A: MAG NAIL SET IN UTILITY POLE BASE 58 61477 4 403.
ELEVATION=82.22'
TBM-B: MAG NAIL SET IN UTILITY POLE 61488 40406 30K 321.
ELEVATION=42.30'
TBM-C: MAG NAIL SET IN ROOT OF 18" DAW.
ELEVATION=14.17'
- TO CONVERT ELEVATION FROM NAV88 (MAP) TO MEAN LOW WATER ADD 1.64 FEET.
PRIOR TO CONSTRUCTION IT IS THE CONTRACTOR'S RESPONSIBILITY TO VERIFY THAT THE BENCHMARKS ILLUSTRATED ON THIS SKETCH HAVE NOT BEEN DISTURBED AND THEIR ELEVATIONS HAVE BEEN CONFIRMED. ANY CONFLICTS MUST BE REPORTED PRIOR TO CONSTRUCTION.
- THE OFFSETS SHOWN ARE NOT TO BE USED FOR THE CONSTRUCTION OF ANY STRUCTURE, FENCE, PERMANENT ADDITION, ETC.
 - BASED ON INFORMATION SHOWN ON MAP REFERENCE NO. 2, AND LIMITED RESEARCH COMPLETED AT NYACK AND ROCKLAND COUNTY CLERK'S OFFICE, RIGHTS, TITLE AND INTEREST OF THE PARCEL SHOWN HEREON WOULD NOT EXTEND BEYOND THE HIGH WATER LINE OF THE HUDSON RIVER.

- REFERENCES:**
- THE OFFICIAL TAX ASSESSOR'S MAP OF VILLAGE OF UPPER NYACK, ROCKLAND COUNTY, NEW YORK, SHEET #66.10.
 - MAP ENTITLED "SURVEY PREPARED FOR 517 N BROADWAY, LLC, TAX MAP SECTION 60.10, BLOCK 1, LOT 19 VILLAGE OF UPPER NYACK - TOWN OF CLARKSON, NEW YORK", PREPARED BY W.E. JAMES ASSOCIATES ENGINEERING, SURVEYING & PLANNING, DATED MARCH 12, 2019.

- LEGEND**
- 124 --- EXISTING CONTOUR
 - 123.45 --- EXISTING SPOT ELEVATION
 - X FF 123.45 --- EXIST. FINISHED FLOOR ELEVATION
 - OVERHEAD WIRES
 - D --- APPROX. LOC. UNDERGROUND DRAINAGE LINE
 - S --- APPROX. LOC. UNDERGROUND SAN. LINE
 - W --- WATER VALVE
 - P.V. --- POINT INDICATOR VALVE
 - G.V. --- GAS VALVE
 - G.M. --- GAS METER
 - E.M. --- ELECTRIC METER
 - SSW --- SANITARY/SEWER MANHOLE
 - UP --- UTILITY POLE
 - MB --- MAIL BOX
 - CB --- CATCH BASIN OR INLET
 - DT --- DECIDUOUS TREE & TRUNK SIZE
 - CT --- CONIFEROUS TREE & TRUNK SIZE
 - W --- WELL
 - ICV --- IRRIGATION CONTROL VALVE
 - CLF --- CHAIN LINK FENCE
 - EOP --- EDGE OF PAVEMENT
 - LSA --- LANDSCAPED AREA
 - TPP --- TYPICAL
 - DTL --- DOUBLE YELLOW LINE
 - B.F.P.A --- BUILDING FOOTPRINT AREA

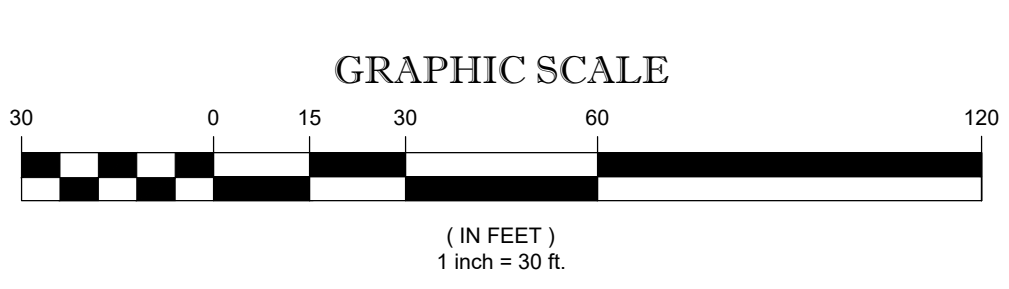
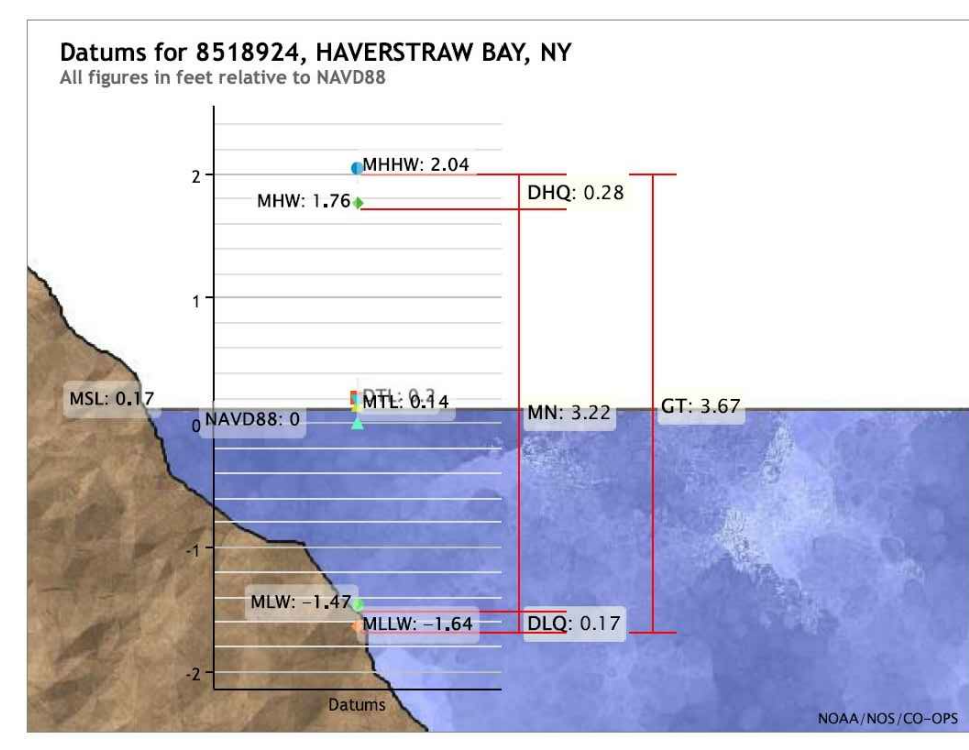

UNAUTHORIZED ALTERATION OR ADDITION TO A SURVEY MAP BEARING A LICENSED LAND SURVEYOR'S SEAL IS A VIOLATION OF SECTION 7209, SUB-DIVISION 2, OF THE NEW YORK STATE EDUCATION LAW.

ONLY COPIES FROM THE ORIGINAL OF THIS SURVEY MARKED WITH AN ORIGINAL OF THE LAND SURVEYOR'S EMBOSSED OR INK SEAL SHALL BE CONSIDERED TO BE VALID TRUE COPIES.

STATE OF NEW YORK
JAMES LOUNSBURY
LICENSED LAND SURVEYOR

James J. Lounsbury
JODY J. LOUNSBURY
NEW YORK PROFESSIONAL LAND SURVEYOR #00715

NOVEMBER 05, 2019
DATE

1	REVISION PER CLIENT COMMENT	-	D.J.D.	J.J.L.	11-05-19
No.	DESCRIPTION OF REVISION	FIELD CREW	DRAWN	APPROVED	DATE
1	10-17-19	19-B			
2	19-8				
3	14-15, 48-49				

TOPOGRAPHIC & BATHYMETRIC SURVEY
517 NORTH BROADWAY

TM# 60.10, BLOCK 1, LOT 19
VILLAGE OF NYACK, ROCKLAND COUNTY
STATE OF NEW YORK

CONTROL POINT ASSOCIATES, INC. PC
17 COMPUTER DRIVE WEST
ALBANY, NY 12205
(518) 750-1100 • (800) 668-9945 FAX
WWW.CONTROLPOINT.COM

ROCHESTER, NY 585 291-1744
WARREN, NJ 908 400-0000
CHESAPEAKE, VA 540 733-3300
NEW YORK, NY 646 760-0111
LONG BEACH, CA 562 591-3344
BOULDER, CO 303 441-3300

REVIEWED: APPROVED: DATE: SCALE: FILE NO: DWG NO:
W.T.W. J.J.L. 10.23.2019 1" = 30' 09-190270 1 OF 1

CONTROL POINT ASSOCIATES, INC. PC - ALL RIGHTS RESERVED. THE SURVEYOR'S SEAL IS A REGISTERED TRADEMARK OF CONTROL POINT ASSOCIATES, INC. IS PROHIBITED.

INDEX OF MARINE DRAWINGS

SHEET	DRAWING	DRAWING TITLE
1	T-01	TITLE SHEET
2	G-01	GENERAL NOTES
3	MR-01	EXISTING PLAN
4	MR-02	PROPOSED PLAN
5	MR-03	PIER AND DOCK PLAN
6	MR-04	PIER AND DOCK ELEVATIONS
7	MR-05	PIER DETAILS 1
8	MR-06	PIER DETAILS 2
9	MR-07	PIER DETAILS 3
10	MR-08	GANGWAY DETAILS
11	MR-09	FLOATING DOCK DETAILS
12	MR-10	MISCELLANEOUS DETAILS

GENERAL NOTES

- ELEVATIONS ARE REFERENCED TO THE NORTH AMERICAN VERTICAL DATUM OF 1988 (NAVD88).
- EXISTING TOPGRAPHIC AND BATHYMETRIC INFORMATION IS BASED ON FIELD SURVEY PERFORMED BY CONTROL POINT ASSOCIATES, INC. DATED OCTOBER 17, 2019 AND REPRESENT CONDITIONS OF THE SITE AT THE TIME OF THE SURVEY.
- TIDAL DATA ARE COMPUTED FROM VDATUM 3.9 SOFTWARE PUBLISHED BY THE NATIONAL OCEANIC AND ATMOSPHERIC ADMINISTRATION.
 - A. MEAN HIGHER HIGH WATER (MHHW) EL. +2.04
 - B. MEAN HIGH WATER (MHW) EL. +1.76
 - C. MEAN LOW WATER (MLW) EL. -1.47
 - D. MEAN LOWER LOW WATER (MLLW) EL. -1.64
- THE OWNER HAS SECURED CERTAIN PERMITS REQUIRED BY FEDERAL AND STATE AUTHORITIES FOR THE PROPOSED ACTIVITIES. IT IS THE RESPONSIBILITY OF THE CONTRACTOR TO PERFORM THE WORK IN ACCORDANCE WITH THE TERMS AND CONDITIONS OF THE PERMITS. THE CONTRACTOR SHALL POST COPIES OF THE PERMITS AT THE SITE THROUGHOUT THE COURSE OF THE WORK. THE CONTRACTOR IS RESPONSIBLE TO OBTAIN PERMITS ASSOCIATED WITH THE LEGAL DISPOSAL OF CONSTRUCTION DEBRIS. THE CONTRACTOR SHALL SECURE REQUIRED LOCAL AUTHORIZATIONS AND PERMITS.
- PRIOR TO CONSTRUCTION AND FABRICATION OF CONSTRUCTION MATERIALS, THE CONTRACTOR SHALL VERIFY EXISTING CONDITIONS AND DIMENSIONS.

DESIGN CRITERIA

- DESIGN CRITERIA ARE IN CONFORMANCE WITH "MINIMUM DESIGN LOADS AND ASSOCIATED CRITERIA FOR BUILDINGS AND OTHER STRUCTURES" PUBLISHED BY THE AMERICAN SOCIETY OF PROFESSIONAL ENGINEERS, 2016 (ASCE 7-16).
- THE FACILITY IS DESIGNED FOR TWO CONDITIONS:
 - A. SERVICE CONDITIONS IS THE MAXIMUM ALLOWABLE ENVIRONMENTAL CONDITIONS IN WHICH THE FACILITY MAY REMAIN IN OPERATION. WHEN ENVIRONMENTAL CONDITIONS ARE EXPECTED TO EXCEED SERVICE CONDITIONS, VESSELS SHALL BE MOVED TO A SAFE HARBOR.
 - B. EXTREME CONDITIONS DENOTE THE MAXIMUM ALLOWABLE ENVIRONMENTAL CONDITIONS WITHIN WHICH THE STRUCTURE IS DESIGNED TO MAINTAIN ITS STRUCTURAL INTEGRITY USING SAFETY FACTORS FROM THE CODE.
- DESIGN LIVE LOAD SHALL BE A UNIFORMLY DISTRIBUTED LOAD OF 50 PSF UNLESS NOTED OTHERWISE. NO LIVE LOADING IS ALLOWED FOR EXTREME CONDITIONS.
- THE FACILITY IS DESIGNED TO ACCOMMODATE MOORING AND BERTHING LOADS ASSOCIATED WITH A BOAT WITH 40 FOOT OVERALL LENGTH. THE FLOATING DOCK IS DESIGNED TO ACCOMMODATE MOORING OF TWO DESIGN VESSELS, ONE ON EITHER SIDE OF THE DOCK, CONCURRENTLY.
- DESIGN WIND LOAD PARAMETERS FOR EXTREME CONDITIONS INCLUDE A BASIC WIND SPEED OF 110 MILES PER HOUR, EXPOSURE CATEGORY C, AND STRUCTURAL OCCUPANCY/RISK CATEGORY I. FOR SERVICE CONDITIONS, THE WIND SPEED IS LIMITED TO 55 MILES PER HOUR.
- EXTREME ENVIRONMENTAL CONDITIONS ARE BASED ON A MAXIMUM WATER LEVEL AT ELEVATION +7.0 PER FEMA FIRM PANELS FOR THE SITE. THE DESIGN WAVE IS CHARACTERIZED BY A SIGNIFICANT WAVE HEIGHT OF 4.2 FEET AND A PERIOD OF 3.1 SECONDS.

EXCAVATION, BACKFILL, AND COMPACTION

- STRUCTURAL FILL SHALL CONSIST OF BROKEN OR CRUSHED STONE, BANK OR CRUSHED GRAVEL, OR MIXTURES THEREOF. BROKEN OR CRUSHED STONE SHALL CONSIST OF WELL-GRADED, SOUND, TOUGH, DURABLE STONE. BANK OR CRUSHED GRAVEL SHALL CONSIST OF WELL-GRADED, SOUND, TOUGH, DURABLE PARTICLES OF CRUSHED OR UNCRUSHED GRAVEL FREE FROM SOFT, THIN, ELONGATED OR LAMINATED PIECES AND ORGANIC OR OTHER DELETERIOUS SUBSTANCES. STRUCTURAL FILL SHALL BE WELL GRADED WITH 100% MASS PASSING THE 3.5 INCH SIEVE. SUBMIT AN INDEPENDENT GRADATION ANALYSIS AND MODIFIED PROCTOR TEST FOR ENGINEER OF RECORD'S REVIEW.
- THE CONTRACTOR SHALL EXCAVATE, BACKFILL, COMPACT, AND GRADE THE SITE TO THE ELEVATIONS AND LIMITS SHOWN AND AS NEEDED TO MEET THE REQUIREMENTS OF THE WORK.
- STRUCTURAL FILL SHALL BE PLACED IN LAYERS NOT MORE THAN 8 INCHES IN LOOSE DEPTH. DO NOT PLACE FILL MATERIAL ON SURFACES THAT ARE MUDDY, FROZEN, OR CONTAINING FROST OR ICE. PLACE FILL MATERIALS EVENLY ADJACENT TO STRUCTURES, TO REQUIRED ELEVATIONS. TAKE CARE TO PREVENT WEDGING ACTION OF BACKFILL AGAINST STRUCTURES BY CARRYING THE MATERIAL UNIFORMLY AROUND THE STRUCTURE TO APPROXIMATELY THE SAME ELEVATION IN EACH LIFT.
- CONTROL STRUCTURAL FILL COMPACTION DURING CONSTRUCTION TO PROVIDE THE MINIMUM PERCENTAGE OF DENSITY SPECIFIED FOR EACH AREA AS DETERMINED ACCORDING TO ASTM D1557. STRUCTURAL FILL AREAS SHALL NOT FALL BELOW 95% OF ITS DENSITY AT OPTIMUM MOISTURE CONTENT AS DETERMINED BY THE ABOVE TEST.

STRUCTURAL STEEL

- STRUCTURAL STEEL SHALL COMPLY WITH THE CURRENT EDITION OF THE "STEEL CONSTRUCTION MANUAL", PUBLISHED BY THE AMERICAN INSTITUTE OF STEEL CONSTRUCTION.
- WELDING SHALL CONFORM TO THE 'STRUCTURAL WELDING CODE - STEEL', AS ADOPTED BY THE AMERICAN WELDING SOCIETY (AWS D1.1).
- WELDING ELECTRODES SHALL BE E70XX AND COMPLY WITH AWS A5.1 AND AWS A5.5.
- STRUCTURAL STEEL PLATES AND SHAPES SHALL CONFORM TO ASTM A572, GRADE 50. STEEL TUBES SHALL CONFORM TO ASTM A500, GRADE B.
- HIGH-STRENGTH BOLTS, NUTS AND WASHERS SHALL BE IN ACCORDANCE WITH "SPECIFICATION FOR STRUCTURAL JOINTS USING ASTM A 325 BOLTS".
- HIGH STRENGTH STRUCTURAL BOLTS SHALL CONFORM TO ASTM A325 WITH HEX HEADS. NUTS SHALL CONFORM TO ASTM A563.
- WASHERS BETWEEN THE BOLT HEAD OR NUT AND STRUCTURAL STEEL SHALL BE HIGH STRENGTH WASHERS CONFORMING TO ASTM F436. WASHERS AGAINST TIMBER SHALL BE COMMON DOCK WASHERS.
- ALL STEEL COMPONENTS SHALL BE HOT-DIP GALVANIZED UNLESS NOTED OTHERWISE. GALVANIZING SHALL CONFORM TO ASTM A123 OR ASTM 153 AS APPLICABLE.
- BOLTED CONNECTIONS SHALL USE 3/4" DIAMETER A 325 HIGH STRENGTH BOLTS UNLESS NOTED OTHERWISE.
- CONNECTIONS SHALL BE DESIGNED AND DETAILED BY THE STEEL FABRICATOR EXCEPT FOR THOSE SPECIFICALLY DETAILED IN THE CONTRACT DOCUMENTS.

TIMBER

- VISUALLY GRADED STRUCTURAL LUMBER AND WOOD CONSTRUCTION SHALL CONFORM TO THE REQUIREMENTS OF THE "NATIONAL DESIGN SPECIFICATION FOR WOOD CONSTRUCTION" AND SUPPLEMENT, "DESIGN VALUES FOR WOOD CONSTRUCTION", NDS 2018, PUBLISHED BY THE NATIONAL FOREST AND PAPER ASSOCIATION.
- TIMBER SHALL MEET THE REQUIREMENTS OF THE SOUTHERN PINE INSPECTION BUREAU, "STANDARD GRADING RULES FOR SOUTHERN PINE LUMBER". TIMBER GRADE SHALL BE NO 1 OR BETTER.
- ALL TIMBER SHALL BE TREATED WITH ALKALINE COPPER QUATERNARY (ACQ) TO A PENETRATION OF 0.60 POUNDS PER CUBIC FOOT.
- CUT AND DRILLED EXPOSED TIMBER AND LUMBER SURFACES SHALL BE LIBERALLY RECOATED BY BRUSH WITH A FIELD TREATMENT ACCEPTED BY THE ENGINEER OF RECORD.

STEEL PILES

- STEEL PIPE PILE MATERIAL SHALL CONFORM TO THE REQUIREMENTS OF ASTM A252, GRADE 3. PILES SHALL BE LONGITUDINALLY WELDED WITH SEAMS SPECIFIED AS COMPLETE PENETRATION WELD.
- STEEL PIPE PILES SHALL BE DRIVEN TO A MINIMUM CAPACITY OR MINIMUM EMBEDMENT LENGTH AS INDICATED ON THE CONTRACT DRAWINGS WHICHEVER IS LARGER.
- DO NOT FIELD SPLICE PILE IN LOWER 40 FEET. BOTH, UPPER AND LOWER SECTIONS OF PILE ENDS, SHALL BE SMOOTH, SQUARE AND FLAT PRIOR TO SPLICING.
- ALL WELDING REQUIRED FOR THE STEEL PIPE PILES SHALL BE FULL PENETRATION WELDS CONFORMING TO AWS D1.1 WELDING CODE AND SHALL BE CAPABLE OF DEVELOPING THE PILE CROSS-SECTION IN TENSION AND BENDING.
- STEEL PIPE PILES SHALL BE SHOP COATED, ON OUTER SURFACES ONLY, TO A MINIMUM OF TEN (10) FEET BELOW THE DESIGN MUDLINE DEPTH ELEVATION OR AS INDICATED ON THE DRAWINGS.

PROTECTIVE COATING

- MATERIAL USED FOR FACTORY EPOXY COATING OF ALL SCHEDULED SURFACES SHALL BE BAR-RUST 235 MULTI-PURPOSE EPOXY COATING AS MANUFACTURED BY DEVCO COATINGS OR EQUIVALENT ACCEPTED BY THE ENGINEER OF RECORD.
- FIELD TOUCH-UP COATING SHALL BE IDENTICAL TO FACTORY COATING AND APPLIED IN ACCORDANCE WITH THE MANUFACTURER'S REQUIREMENTS.
- PROTECTIVE COATING TOP COAT SHALL BE BLACK UNLESS OTHERWISE INDICATED ON THE DRAWINGS OR BY THE OWNER.
- SURFACES SHALL BE PREPARED IN STRICT ACCORDANCE WITH THE PROTECTIVE COATING SYSTEM MANUFACTURER'S WRITTEN INSTRUCTIONS.
- THE PROTECTIVE COATING SHALL BE INSTALLED IN STRICT ACCORDANCE WITH MANUFACTURER'S WRITTEN INSTRUCTIONS. COATING IS TO BE APPLIED IN TWO COATS TO ACHIEVE A MINIMUM OVERALL DRY FILM THICKNESS OF 15 MILS.
- ALL HOLIDAYS OR OTHER IMPERFECTIONS IN THE COATING SHALL BE REMOVED OR REPAIRED AT THE CONTRACTORS EXPENSE PRIOR TO FINAL ACCEPTANCE OF THE WORK.

PILE DRIVING

- INSTALL PILES USING VIBRATORY METHODS TO CAPACITY AND TOE ELEVATIONS WITHOUT DAMAGING THE PILE HEAD. WHERE REQUIRED, CUT OFF HEADS OF PILES ACCURATELY IN ACCORDANCE WITH THE CONTRACT DOCUMENTS AFTER COMPLETION OF DRIVING.
- DRIVE THE PILES STRAIGHT AND TRUE AT INDICATED LOCATIONS, WITH DEVIATION FROM THE LONGITUDINAL AXIS OF NOT MORE THAN 1/4 INCH PER FOOT.
- LOCATE THE PILES WITHIN 3 INCHES OF THE POSITIONS INDICATED ON THE DRAWINGS.
- WITHDRAW PILES THAT ENCOUNTER UNDERGROUND OBSTRUCTIONS SUFFICIENT TO IMPEDE PILE DRIVING. RE-DRIVE AS CLOSE AS POSSIBLE TO ORIGINAL POSITION, SUBJECT TO REVIEW OF THE OWNER. REMOVE PILES WHICH BREAK OR DRIVE OUT OF LINE. DRIVE ANOTHER PILE IN ITS PLACE.
- DRIVE PILES TO THEIR FULL PENETRATION WITHOUT BENDING, RUPTURING, OR MODERATELY DAMAGING THE PILES. IF FAILURE IN THE ABOVE RESPECTS IS ENCOUNTERED, PULL THE PILE AND DRIVE A NEW PILE AT NO ADDITIONAL COST TO THE OWNER.
- JETTING TO ASSIST PENETRATION WILL NOT BE PERMITTED UNLESS ACCEPTED BY THE ENGINEER OF RECORD. WHERE ACCEPTED, PRE-DRILLING TO ASSIST PENETRATION MAY BE USED WHERE EXTREME DRIVING RESISTANCE IS ENCOUNTERED, OR WHERE VIBRATIONS FROM DRIVING MAY BE DETRIMENTAL TO ADJACENT STRUCTURES.
- WHERE PILES ARE PUSHED UP BY PRESSURE FROM DRIVING OF ADJACENT PILES, RE-DRIVE AS REQUIRED AND AT NO ADDITIONAL COST TO THE OWNER.

ABBREVIATIONS AND SYMBOLS

ADD'L	ADDITIONAL
ALT.	ALTERNATE
BOT.	BOTTOM
CLR.	CLEAR
COL.	COLUMN
CONC.	CONCRETE
DWG.	DRAWING
EA.	EACH
EF.	EACH FACE
EL.	ELEVATION
EQ.	EQUAL
EXIST.	EXISTING
FT. OR GALV.	FOOT GALVANIZED
H.D.G.	HOT-DIP GALVANIZED
I.D.	INSIDE DIAMETER
IN. OR "	INCHES
KSL.	KIPS PER SQUARE INCH
LONG.	LONGITUDINAL
MAX.	MAXIMUM
N.	NORTH
N.I.C.	NOT IN CONTRACT
O.C.	ON CENTER
O.D.	OUTSIDE DIAMETER
OPP.	OPPOSITE
PL.	PLATE
PSI.	POUNDS PER SQUARE INCH
PSF.	POUNDS PER SQUARE FOOT
R	RADIUS
REINF.	REINFORCING
REF.	REFERENCE
REQD.	REQUIRED
S.	SOUTH
SECT.	SECTION
SIM.	SIMILAR
SPA.	SPACING
SS.	STAINLESS STEEL
TYP.	TYPICAL
U.O.N.	UNLESS OTHERWISE NOTED
⊕	CENTERLINE
∅	DIAMETER
±	PLUS OR MINUS
	NORTH ARROW

DRAWING CONVENTIONS

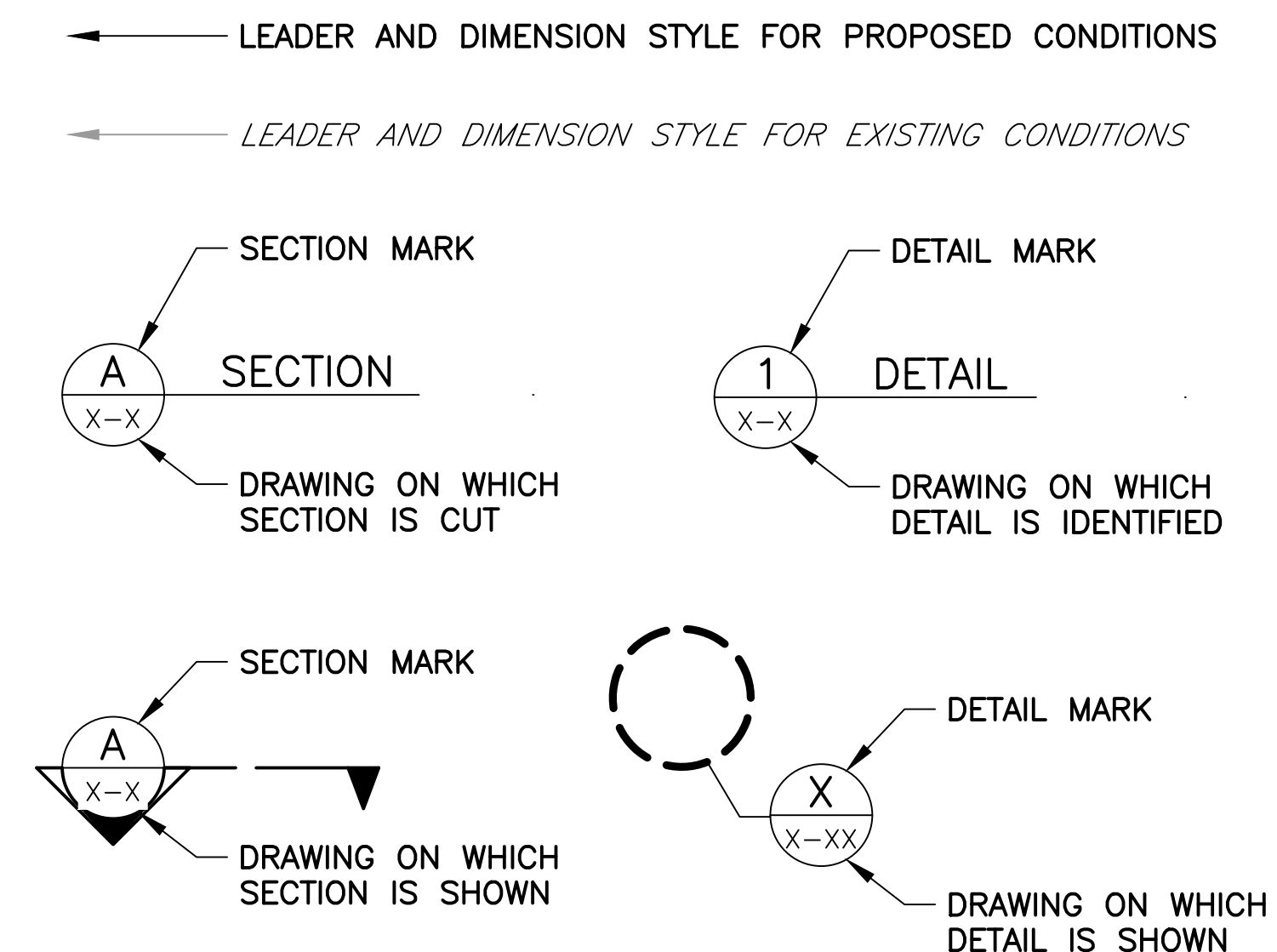

NO.	DATE	REVISION	BY	PREPARED BY	MADE BY		<p align="center">ISSUED FOR CONSTRUCTION</p>	PREPARED FOR	TITLE OF PROJECT	DRAWING TITLE	DRAWING NO.
1	05/26/21	ADDRESS VILLAGE COMMENTS	BDB		B. BUCKMAN			RAZ TIROSH 517 NORTH BROADWAY UPPER NYACK, NY 10960	SEAWALL REHABILITATION AND DOCK INSTALLATION	GENERAL NOTES	G-01
					B. BUCKMAN				PROJECT LOCATION		DATE
					B. BUCKMAN				517 NORTH BROADWAY UPPER NYACK, NY		4/1/2021
										REVISION NO.	1
										SHEET NO.	2 OF 12

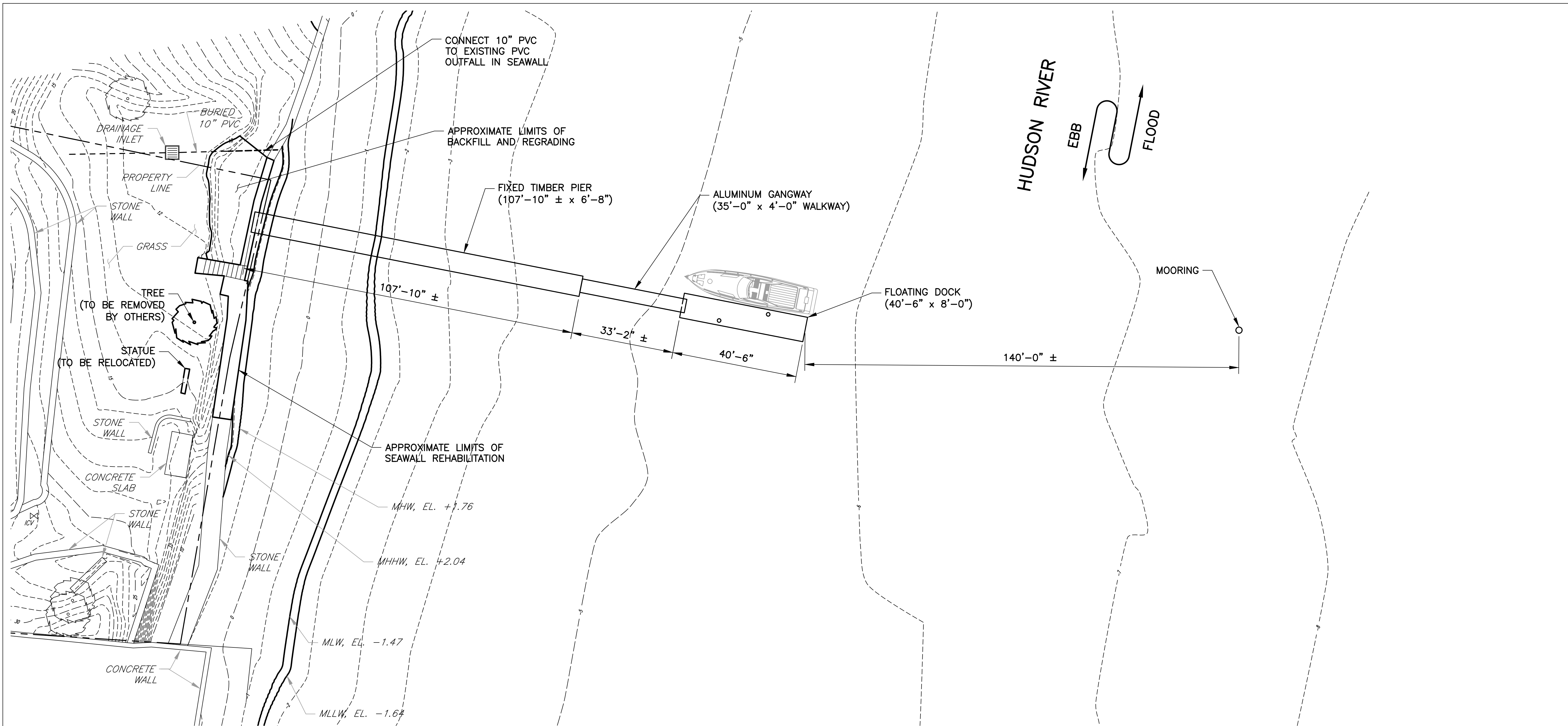

PROPOSED PLAN

NOTES

- ELEVATIONS ARE REFERENCED TO THE NORTH AMERICAN VERTICAL DATUM OF 1988 (NAVD88).
- EXISTING TOPGRAPHIC AND BATHYMETRIC INFORMATION IS BASED ON FIELD SURVEY PERFORMED BY CONTROL POINT ASSOCIATES, INC. DATED OCTOBER 17, 2019 AND REPRESENT CONDITIONS OF THE SITE AT THE TIME OF THE SURVEY.
- COORDINATE WITH OWNER TO DETERMINE LOCATION TO WHERE STATUE WILL BE RELOCATED. OWNER MAY ELECT TO HAVE CONTRACTOR DISPOSE OF STATUE.
- REHABILITATION OF EXISTING SEAWALL SHALL BE PERFORMED BY A CONTRACTOR EXPERIENCED IN BUILDING AND REHABILITATING NATURAL STONE SEAWALLS.
- FOR DETAILED BREAKDOWN OF SEAWALL REPAIRS, REFER TO "PIER AND DOCK PLAN" DRAWING.

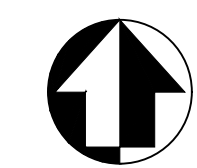

NO.	DATE	REVISION	BY	PREPARED BY	MADE BY	ISSUED FOR CONSTRUCTION	PREPARED FOR	TITLE OF PROJECT	DRAWING TITLE	DRAWING NO.			
				BUCKMAN	B. BUCKMAN		RAZ TIROSH 517 NORTH BROADWAY UPPER NYACK, NY 10960	SEAWALL REHABILITATION AND DOCK INSTALLATION PROJECT LOCATION 517 NORTH BROADWAY UPPER NYACK, NY	PROPOSED PLAN	MR-02			
				B. BUCKMAN									DATE 4/1/2021
				B. BUCKMAN									REVISION NO. 0
				BUCKMAN ENGINEERING, PLLC 255 DEAN STREET BROOKLYN, NY 11217	PROJECT NO. 19051								SHEET NO. 4 OF 12

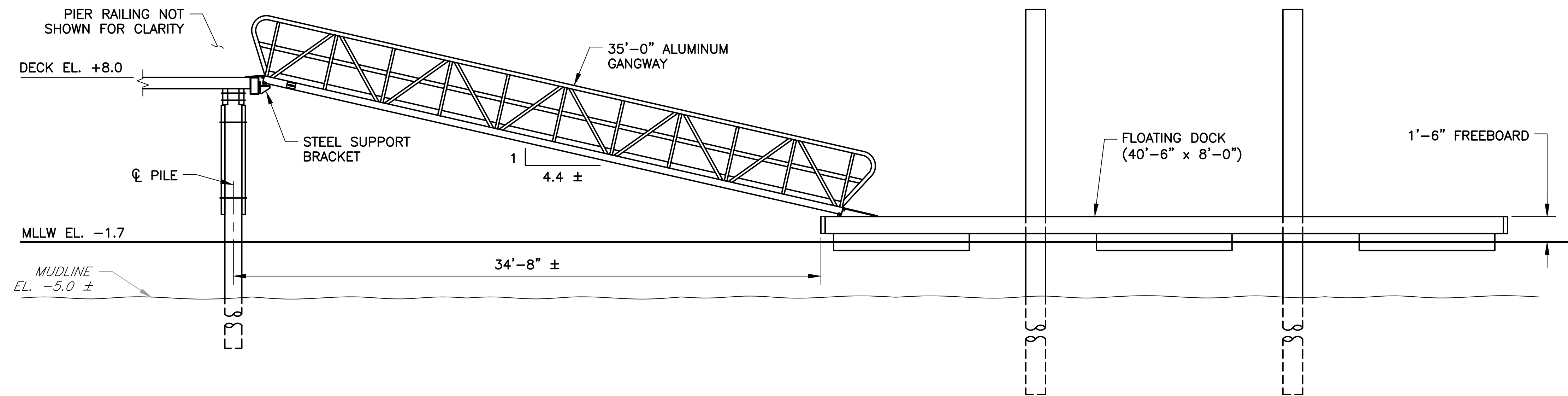

TYPICAL PIER FRAMING PLAN

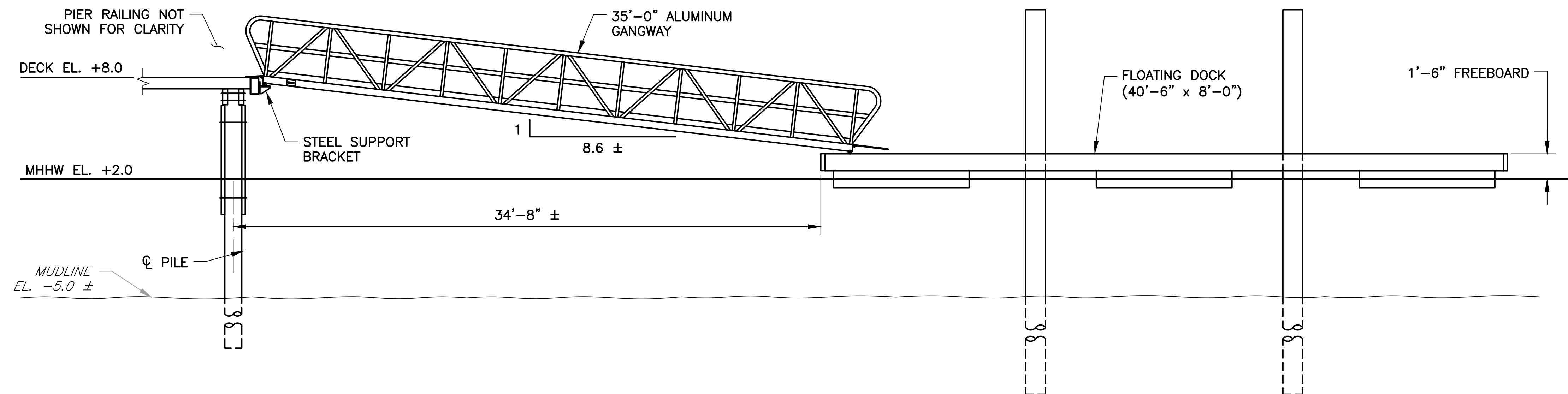

NO.	DATE	REVISION	BY
1	05/26/21	REVISED PIER FRAMING	BDB

PREPARED BY
BUCKMAN
 BUCKMAN ENGINEERING, PLLC
 255 DEAN STREET
 BROOKLYN, NY 11217

MADE BY
 B. BUCKMAN
 DRAWN BY
 B. BUCKMAN
 CHECKED BY
 B. BUCKMAN
 PROJECT NO.
 19051



ISSUED FOR CONSTRUCTION

WARNING - IT IS A VIOLATION OF SECTION 7209 OF THE STATE EDUCATION LAW FOR ANY PERSON TO ALTER THIS DRAWING IN ANY WAY UNLESS ACTING UNDER THE DIRECTION OF A LICENSED PROFESSIONAL ENGINEER. THE ALTERING ENGINEER SHALL AFFIX THEIR SEAL AND THE NOTATION "ALTERED BY" FOLLOWED BY THEIR SIGNATURE, THE DATE OF ALTERATION, AND A SPECIFIC DESCRIPTION OF THE ALTERATION.

PREPARED FOR
 RAZ TIROSH
 517 NORTH BROADWAY
 UPPER NYACK, NY 10960

TITLE OF PROJECT
SEAWALL REHABILITATION AND DOCK INSTALLATION
 PROJECT LOCATION
 517 NORTH BROADWAY
 UPPER NYACK, NY

DRAWING TITLE
PIER AND DOCK ELEVATIONS

DRAWING NO.
MR-04
 DATE
 4/1/2021
 REVISION NO.
 1
 SHEET NO.
 6 OF 12

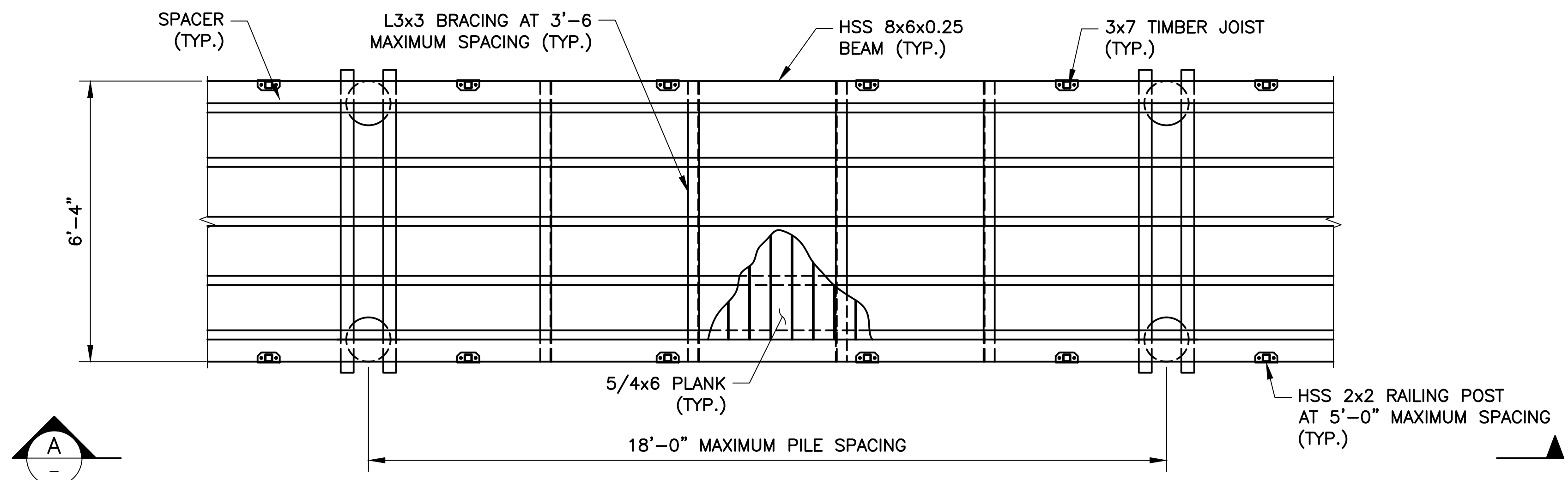

TYPICAL PIER FRAMING PLAN

NOTES

1. UNLESS NOTED OTHERWISE, PIER FRAMING AND DECKING ARE BUILT FROM PRESSURE TREATED TIMBER.
2. FOR DECK FRAMING DETAILS, REFER TO DRAWING "PIER DETAILS 2".
3. CABLE RAILING RAILING SHALL BE 3/16 INCH MINIMUM DIAMETER STAINLESS STEEL CABLE. THE CABLE RAILING SHALL BE PROVIDED AS MANUFACTURED KIT INCLUDING ANCHORAGE HARDWARE TO POST AND TENSIONING HARDWARE.
4. CONTRACTOR SHALL SUBMIT TO THE ENGINEER FOR REVIEW AND APPROVAL SHOP DRAWINGS OF THE POSTS, TOP RAILING, AND CABLE RAILS TO DEMONSTRATE SUPPORTING MEMBERS ARE PROPERLY COORDINATED WITH CABLE RAILING. SHOP DRAWINGS SHALL SHOW THE DETAILS OF THE ASSEMBLY AND CONNECTION DETAILS AS WELL AS THE PROCEDURE FOR INSTALLING THE CABLE RAILS.
5. CONTRACTOR MAY SUBMIT AN ALTERNATE POST AND RAIL SYSTEM TO THE ENGINEER AND OWNER FOR REVIEW AND APPROVAL PROVIDED THE SYSTEM HAS SIMILAR TOP RAIL SIZE, POST SIZE AND POST SPACING DEPICTED ON THESE PLANS. THE ALTERNATE SYSTEM SHALL BE SIMILAR IN APPEARANCE TO THE CURRENTLY PROPOSED RAILING TO BE DETERMINED SOLELY BY THE ENGINEER AND OWNER. THE CONTRACTOR MUST DEMONSTRATE THAT THE ALTERNATIVE SYSTEM CAN SAFELY SUPPORT THE RAILING LOADS PRESCRIBED IN ASCE 7-16.

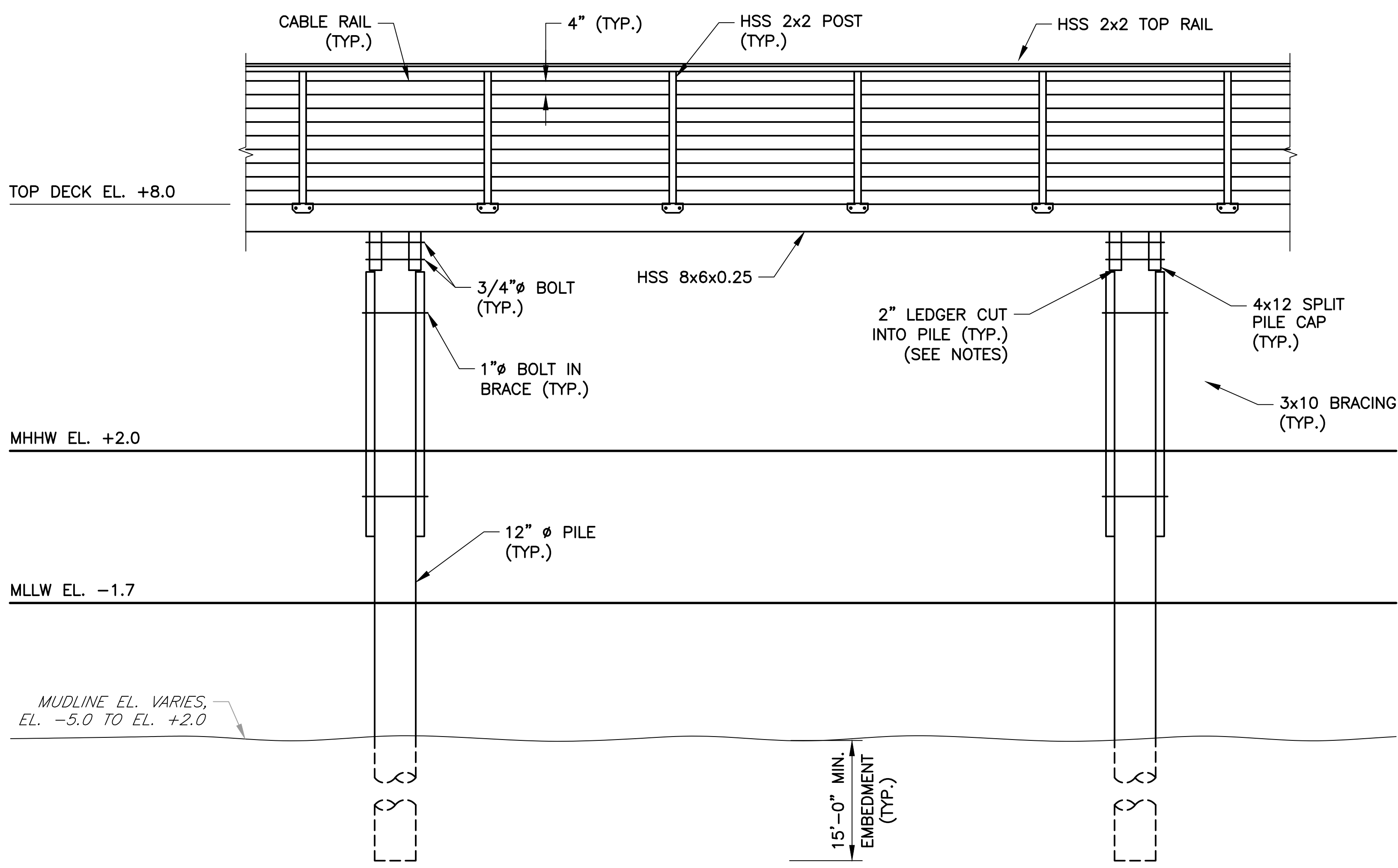

(A) ELEVATION VIEW

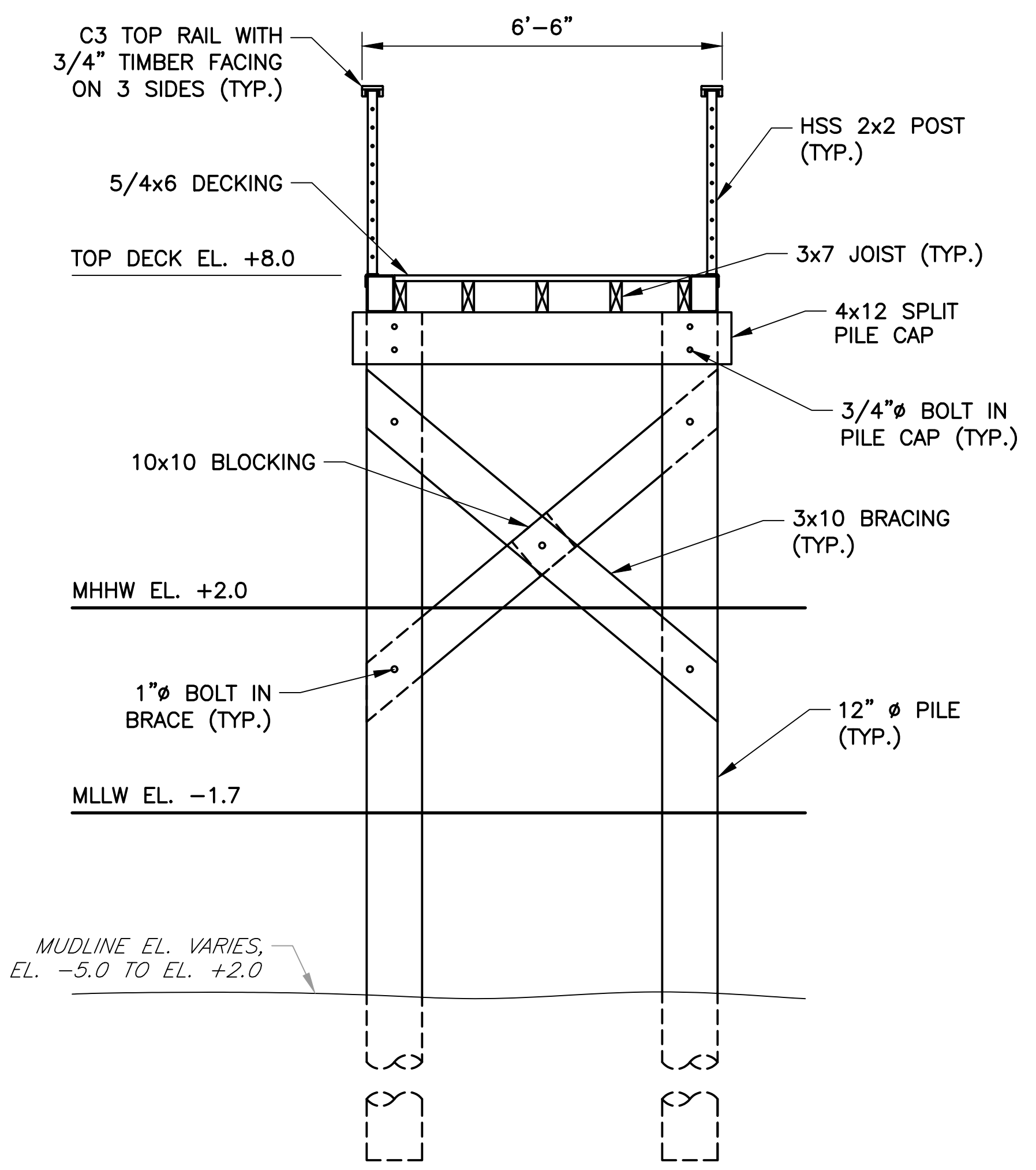

(B) TYPICAL SECTION



NO.	DATE	REVISION	BY	PREPARED BY	MADE BY		<p>ISSUED FOR CONSTRUCTION</p>	PREPARED FOR	TITLE OF PROJECT	DRAWING TITLE	DRAWING NO.	
1	05/26/21	REVISED PIER FRAMING	BDB		B. BUCKMAN			RAZ TIROSH 517 NORTH BROADWAY UPPER NYACK, NY 10960	SEAWALL REHABILITATION AND DOCK INSTALLATION	<p>PIER DETAILS 1</p>	MR-05	
					B. BUCKMAN						DATE	4/1/2021
					B. BUCKMAN						REVISION NO.	1
								PROJECT LOCATION			SHEET NO.	
								517 NORTH BROADWAY UPPER NYACK, NY			7 OF 12	

BUCKMAN

BUCKMAN ENGINEERING, PLLC
255 DEAN STREET
BROOKLYN, NY 11217

19051

WARNING - IT IS A VIOLATION OF SECTION 7209 OF THE STATE EDUCATION LAW FOR ANY PERSON TO ALTER THIS DRAWING IN ANY WAY UNLESS ACTING UNDER THE DIRECTION OF A LICENSED PROFESSIONAL ENGINEER. THE ALTERING ENGINEER SHALL AFFIX THEIR SEAL AND THE NOTATION "ALTERED BY" FOLLOWED BY THEIR SIGNATURE, THE DATE OF ALTERATION, AND A SPECIFIC DESCRIPTION OF THE ALTERATION.

NOTES

1. FOR TYPICAL PIER FRAMING PLAN, REFER TO DRAWING "PIER DETAILS 1".
2. L3x3x3/16 CONNECTION ANGLE SHALL CONFORM TO ASTM A36 AND SHALL BE HOT-DIP GALVANIZED PER ASTM A123. FASTEN USING TWO 3/4" BOLTS INTO BOTH THE JOIST AND SPLIT CAP BEAM. PROVIDE STANDARD WASHER BETWEEN BOLT HEAD AND ANGLE. PROVIDE OVERSIZE PLATE WASHER OR OGEE WASHER BETWEEN NUT AND TIMBER BEAM. BOLTS, NUTS, AND WASHERS SHALL BE HOT-DIP GALVANIZED PER ASTM A153.

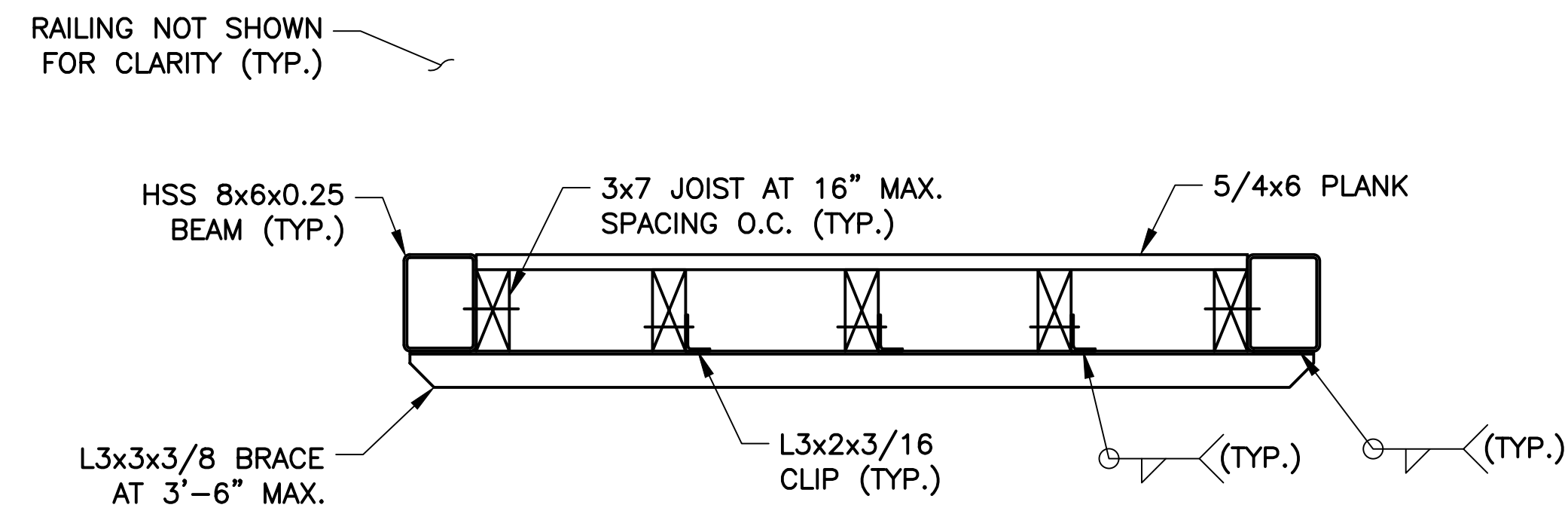

SECTION AT L3x3 BRACE
SCALE (B)

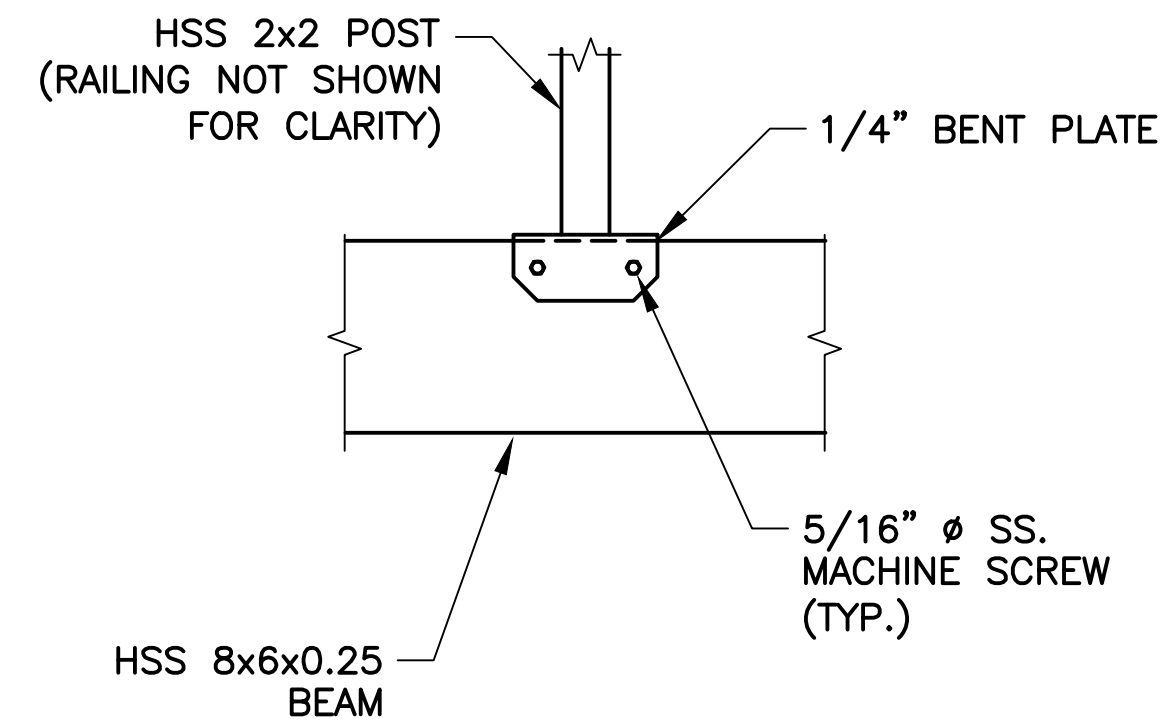

RAILING POST MOUNTING DETAIL - ELEVATION
SCALE (A)

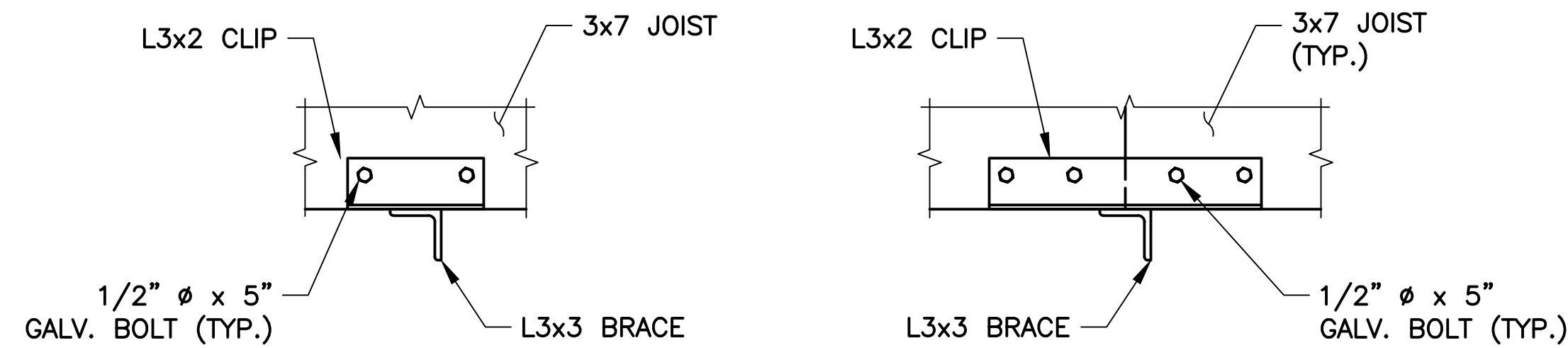

JOIST CLIP DETAILS
SCALE (A)

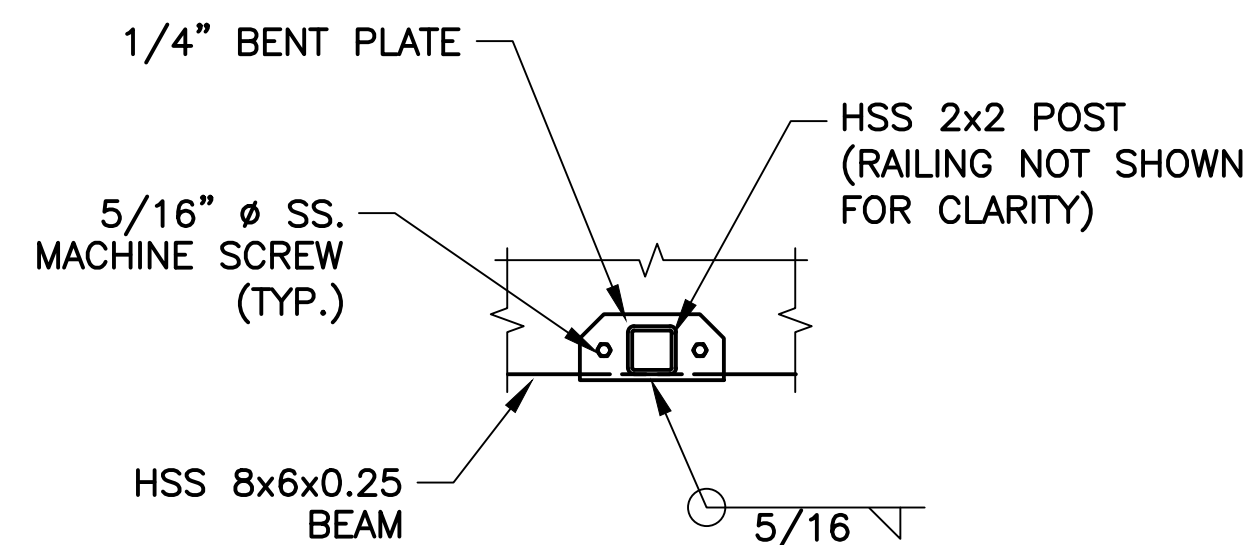

RAILING POST MOUNTING DETAIL - PLAN
SCALE (A)

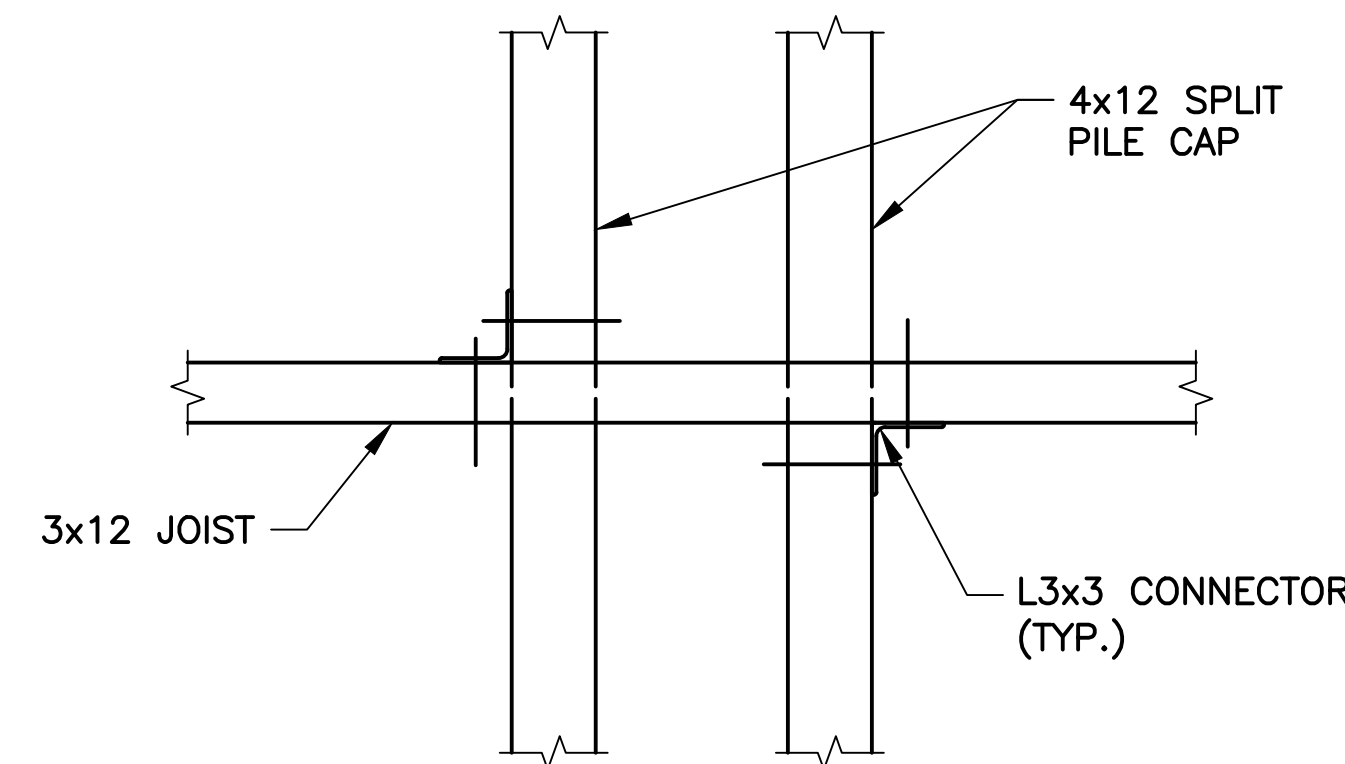

JOIST-CAP CONNECTION DETAIL
SCALE (A)

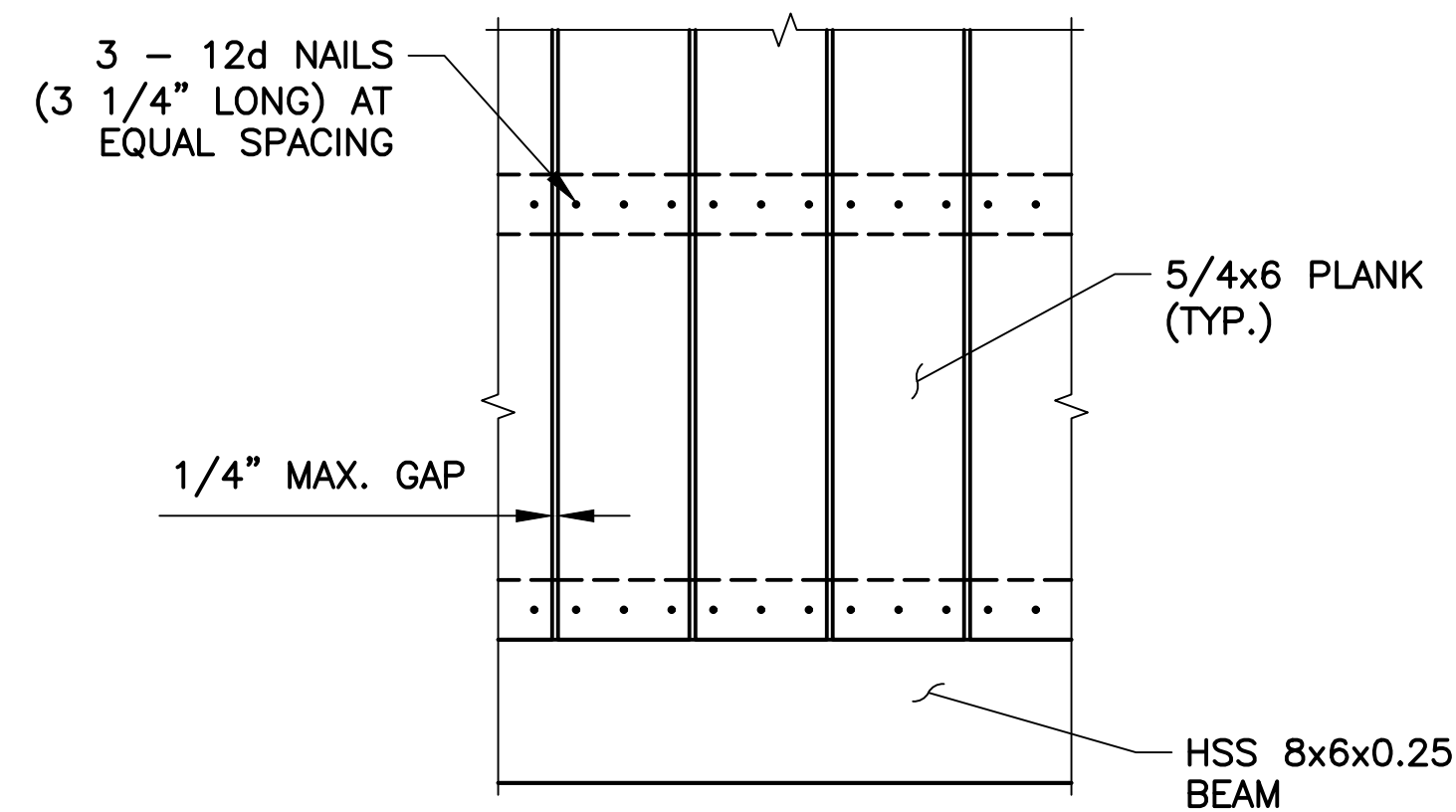

DECK FASTENING DETAIL
SCALE (A)

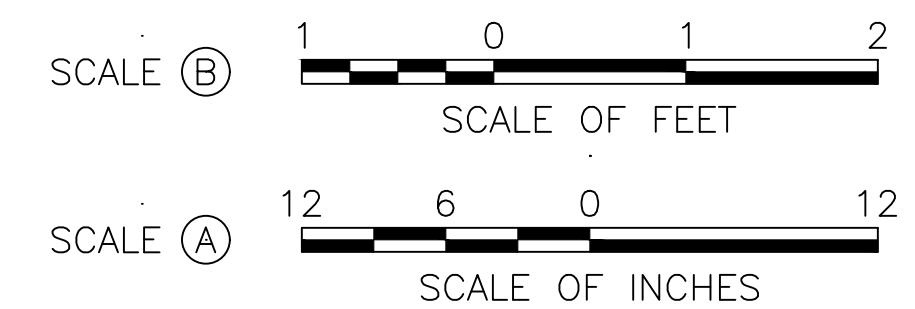

NO.	DATE	REVISION	BY	PREPARED BY	MADE BY	PROJECT NO.	ISSUED FOR CONSTRUCTION	PREPARED FOR	TITLE OF PROJECT	DRAWING TITLE	DRAWING NO.
1	05/26/21	ADDRESS VILLAGE COMMENTS	BDB	BUCKMAN	B. BUCKMAN	19051	ISSUED FOR CONSTRUCTION	RAZ TIROSH 517 NORTH BROADWAY UPPER NYACK, NY 10960	SEAWALL REHABILITATION AND DOCK INSTALLATION	PIER DETAILS 2	MR-06
					B. BUCKMAN						DATE 4/1/2021
					B. BUCKMAN						REVISION NO. 1
											SHEET NO. 8 OF 12

NOTES

1. CONTRACTOR SHALL PROVIDE TO THE ENGINEER FOR REVIEW AND APPROVAL SHOP DRAWINGS OF THE GANGWAY SUPPORT BRACKET WITH NECESSARY MODIFICATIONS INDICATED BY THE GANGWAY MANUFACTURE TO ACCOMMODATE THEIR SYSTEM INCLUDING, BUT NOT LIMITED TO, FIFTH WHEEL CONNECTION, SAFETY CHAIN CONNECTION, AND HEIGHT OF SEAT PLATE BELOW TOP OF DECK.
2. THE GANGWAY SUPPORT BRACKET SHOP DRAWINGS SHALL ALSO SHOW THE CONNECTIONS FOR THE RAILING POST.
3. THE GANGWAY SUPPORT BRACKET AND ITS CONNECTION HARDWARE SHALL BE HOT-DIP GALVANIZED.

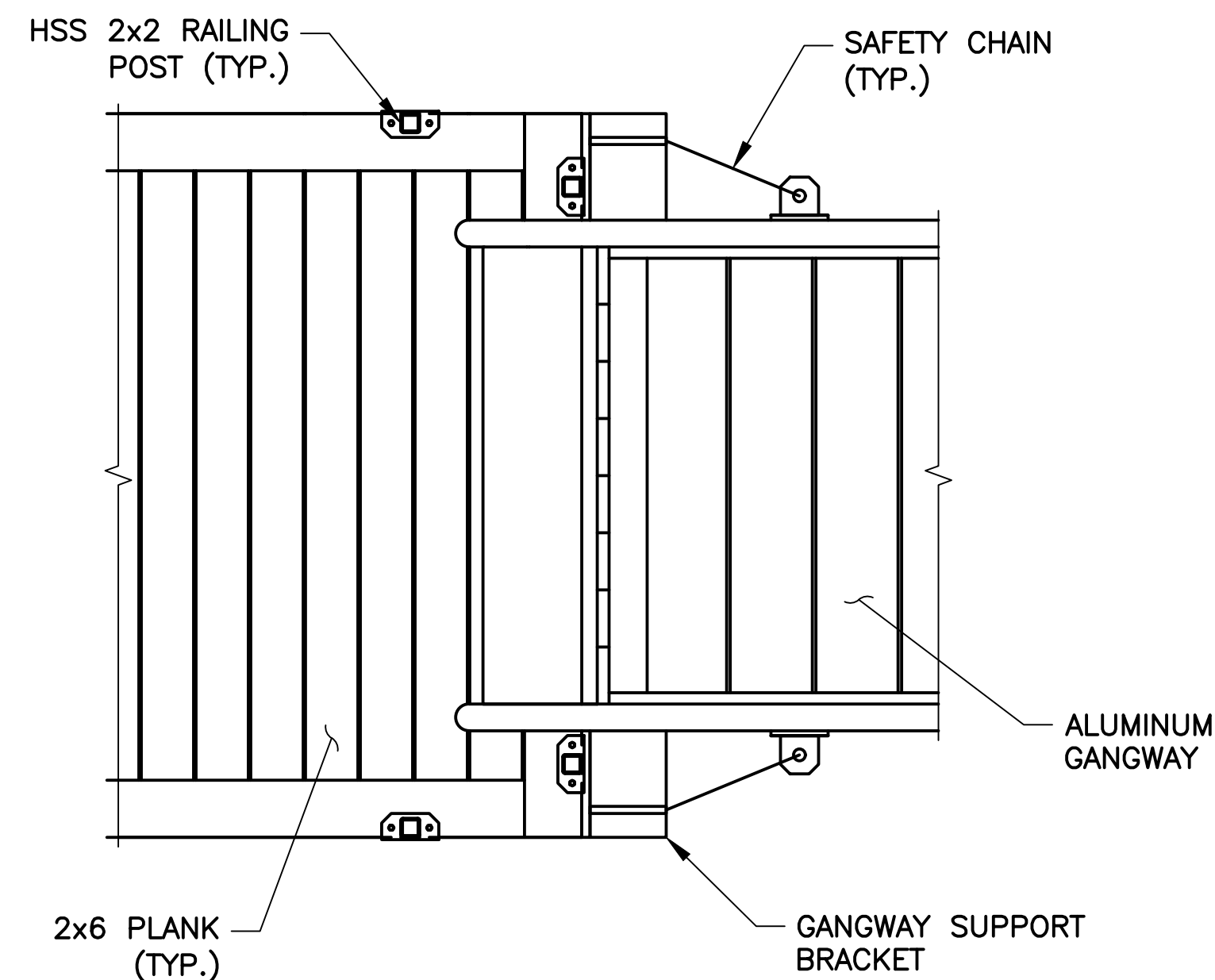

PIER PLAN AT GANGWAY BRACKET
SCALE (A)

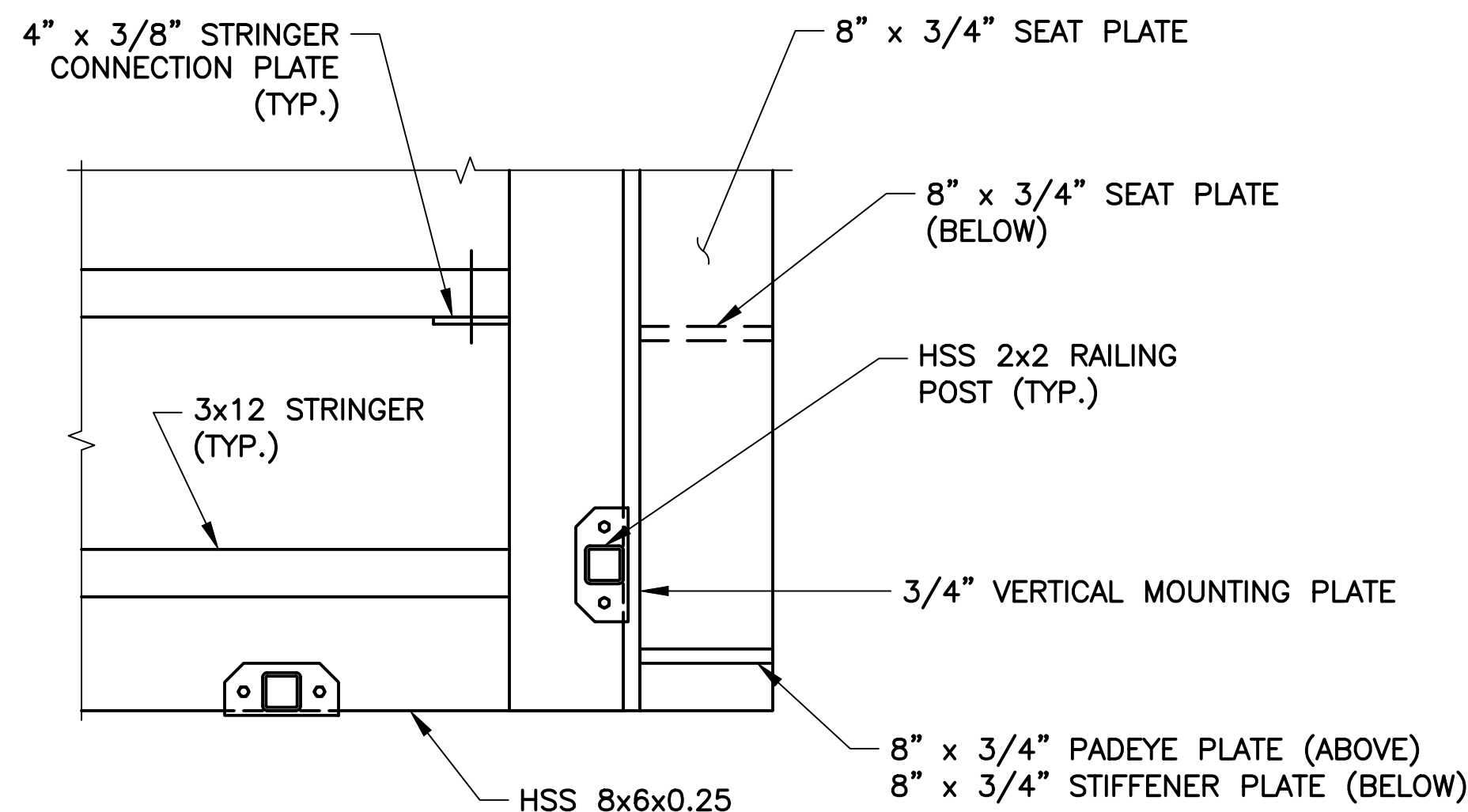

1 BRACKET DETAIL
SCALE (B)

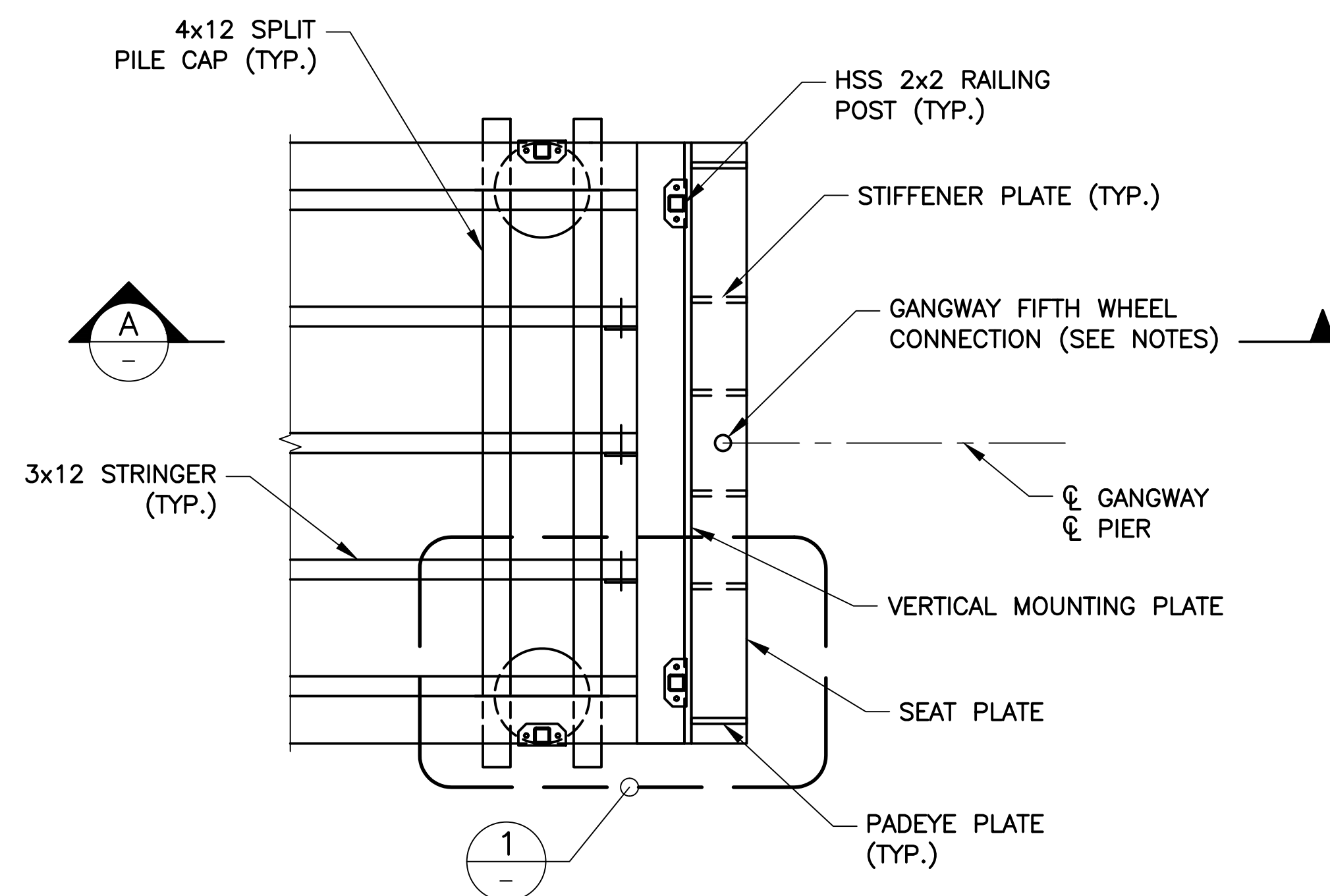

PIER FRAMING AT GANGWAY BRACKET
SCALE (A)

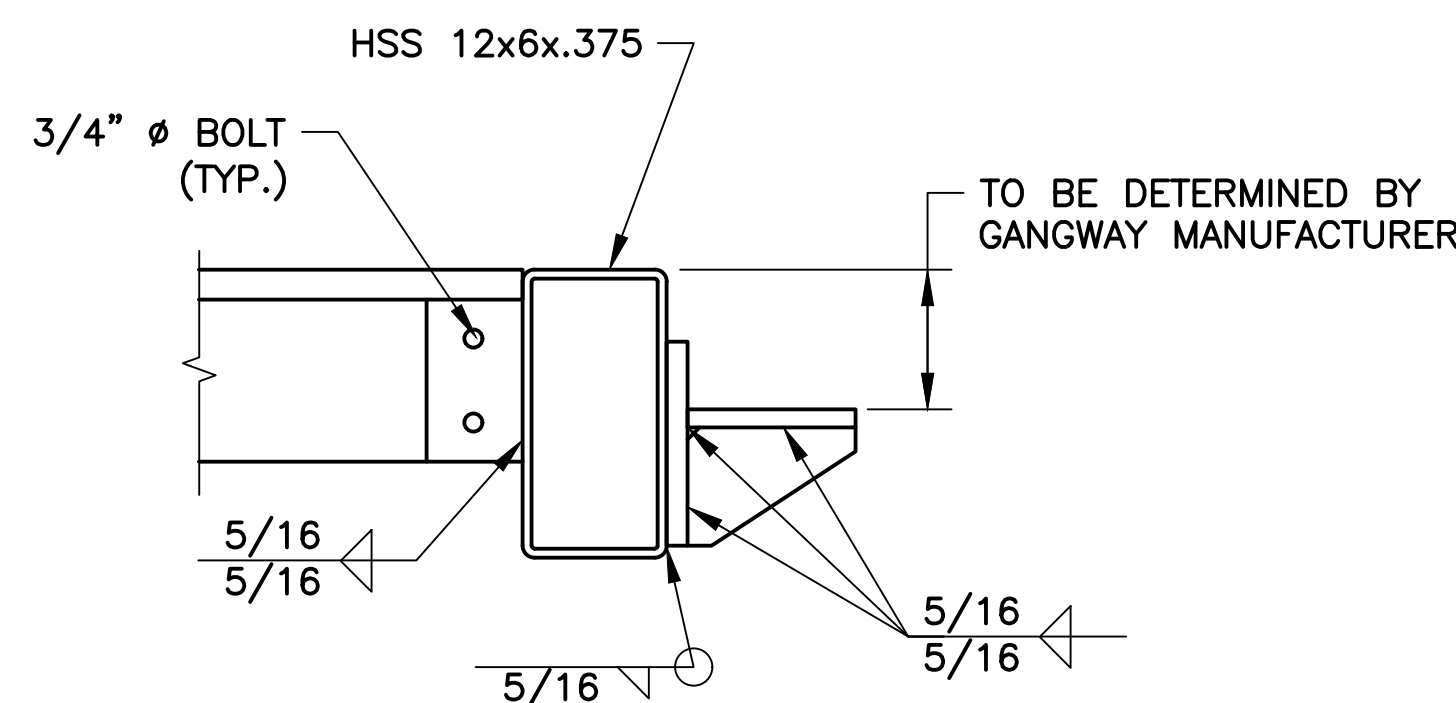

A SECTION THROUGH BRACKET
SCALE (B)

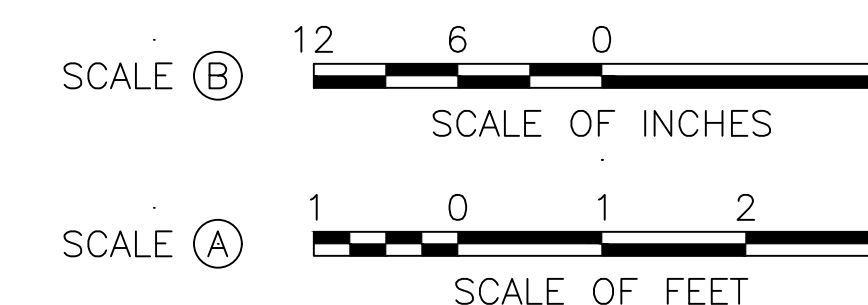

NO.	DATE	REVISION	BY	PREPARED BY	MADE BY	PROJECT NO.	ISSUED FOR CONSTRUCTION	PREPARED FOR	TITLE OF PROJECT	DRAWING TITLE	DRAWING NO.
1	05/26/21	REVISED PIER FRAMING	BDB		B. BUCKMAN	19051	ISSUED FOR CONSTRUCTION	RAZ TIROSH 517 NORTH BROADWAY UPPER NYACK, NY 10960	SEAWALL REHABILITATION AND DOCK INSTALLATION	PIER DETAILS 3	MR-07
					B. BUCKMAN						DATE 4/1/2021
					B. BUCKMAN						REVISION NO. 1
											SHEET NO. 9 OF 12

BUCKMAN

BUCKMAN ENGINEERING, PLLC
255 DEAN STREET
BROOKLYN, NY 11217



WARNING - IT IS A VIOLATION OF SECTION 7209 OF THE STATE EDUCATION LAW FOR ANY PERSON TO ALTER THIS DRAWING IN ANY WAY UNLESS ACTING UNDER THE DIRECTION OF A LICENSED PROFESSIONAL ENGINEER. THE ALTERING ENGINEER SHALL AFFIX THEIR SEAL AND THE NOTATION "ALTERED BY" FOLLOWED BY THEIR SIGNATURE, THE DATE OF ALTERATION, AND A SPECIFIC DESCRIPTION OF THE ALTERATION.

517 NORTH BROADWAY
UPPER NYACK, NY

PIER DETAILS 3

GANGWAY NOTES

1. THE WORK COVERED UNDER THIS SECTION SHALL CONSIST OF MANUFACTURING AND SUPPLYING OF A PREFABRICATED ALUMINUM GANGWAY AS SHOWN IN THE PLANS. ALL MATERIALS SHALL BE MANUFACTURED OR DISTRIBUTED BY RAVENS MARINE OR APPROVED EQUAL.
2. THE GANGWAY SHALL BE DESIGNED WITH MINIMUM SAFETY FACTORS ON WORKING STRESS WHICH CONFORM TO THOSE SET FORTH IN THE LATEST ISSUE OF THE ALUMINUM ASSOCIATION "SPECIFICATIONS FOR ALUMINUM STRUCTURES" FOR BUILDINGS AND SIMILAR TYPE STRUCTURES. TO ENSURE SPECIFIED CRITERIA HAVE BEEN MET, THE CONTRACTOR SHALL SUBMIT THE FOLLOWING:
 - A. SHOP DRAWINGS SHOWING DIMENSIONAL LAYOUT OF THE GANGWAY.
 - B. SHOP DRAWINGS SHOWING CONNECTION DETAILS INCLUDING, BUT NOT LIMITED TO, ROLLER BEARINGS, FIFTH WHEEL CONNECTION, RAILINGS, TRANSITION RAMPS, AND PLANKS.
 - C. ENGINEERING CALCULATIONS SHOWING COMPLIANCE WITH THE DESIGN CRITERIA SPECIFIED HEREIN. CALCULATIONS MUST BE SIGNED AND SEALED BY AN ENGINEER LICENSED TO PRACTICE IN THE STATE OF NEW YORK.
3. ALUMINUM EXTRUSIONS FOR GANGWAY STRUCTURES SHALL BE ALUMINUM ALLOY 6061-T6 EXTRUDED IN ACCORDANCE WITH THE REQUIREMENTS OF FEDERAL SPECIFICATION QQ-A-200.
4. STAINLESS STEEL BOLTS, NUTS, WASHERS, AND SCREWS SHALL BE TYPE 304.
5. ROLLER BEARINGS SHALL BE UHMW POLYURETHANE WITH BLACK ULTRAVIOLET LIGHT INHIBITOR ADDED.
6. EXTRUDED RIBBED DECKING SHALL BE DESIGNED TO WITHSTAND A COMBINED DEAD LOAD AND LIVE LOAD OF 100 POUNDS PER SQUARE FOOT PER INDIVIDUAL SLAT WITH AN ALLOWABLE DEFLECTION OF L/180 WHERE "L" IS THE SPAN OF THE DECKING.
7. HANDRAILS SHALL BE DESIGNED TO WITHSTAND A CONCENTRATED LOAD OF 200 POUNDS OR A LINEAR LOAD OF 50 POUNDS PER LINEAR FOOT, WHICHEVER PRODUCES MAXIMUM EFFECT. INTERMEDIATE RAILS SHALL BE DESIGNED FOR A CONCENTRATED LOAD OF 50 POUNDS. THE RAILS SHALL BE DESIGNED TO WITHSTAND THE LOADS ACTING IN ANY DIRECTION.
8. GANGWAYS SHALL BE DESIGNED TO WITHSTAND A UNIFORM LIVE LOAD OF 50 POUNDS PER SQUARE FOOT APPLIED VERTICALLY. ALLOWABLE DEFLECTION SHALL BE A MAXIMUM OF L/180 WHERE "L" IS THE LENGTH OF THE GANGWAY.
9. DECKING SHALL BE EXTRUDED ALUMINUM SLATS TO PROVIDE A NON-SKID SURFACE AND SHALL NOT EXCEED 9 INCHES IN WIDTH AND NOT MORE THAN 3/8 INCH AIR SPACE BETWEEN THE SLATS. THE LEGS OF EACH SLAT SHALL BE WELDED TO THE SIDE MEMBERS WITH A MINIMUM OF 1-1/4 INCHES OF WELD PER LEG. DECKING SLATS SHALL BE PLACED TRANSVERSELY ON THE GANGWAY.
10. HINGED TRANSITION PLATES SHALL HAVE A NON-SKID SURFACE MADE OF DIAMOND PLATE, RIBBED PLATE, SLIP-NOT COATING, OR APPROVED EQUAL.
11. HINGE MOUNT EXTRUSIONS SHALL BE WELDED TO THE FRAME OF THE DOCK WITH A CONTINUOUS FILLET WELD UNLESS OTHERWISE SHOWN ON THE PLANS.
12. ANY POTENTIALLY CORROSIVE INSTALLATION OF DISSIMILAR METALS SHALL BE PROPERLY INSULATED TO MINIMIZE OR ELIMINATE CORROSION IN A MARINE ENVIRONMENT.
13. GANGWAYS SHALL BE SECURELY FASTENED TO THE DOCK. MANUFACTURER SHALL DESIGN THE FIFTH WHEEL CONNECTION AND INDICATE ANY MODIFICATIONS TO THE STEEL SUPPORT BRACKET NECESSARY TO ACCOMMODATE THE GANGWAY CONNECTION.

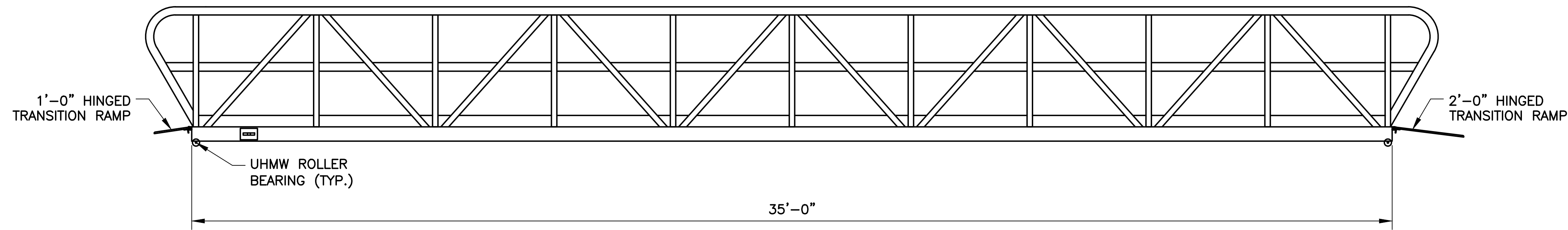

GANGWAY ELEVATION

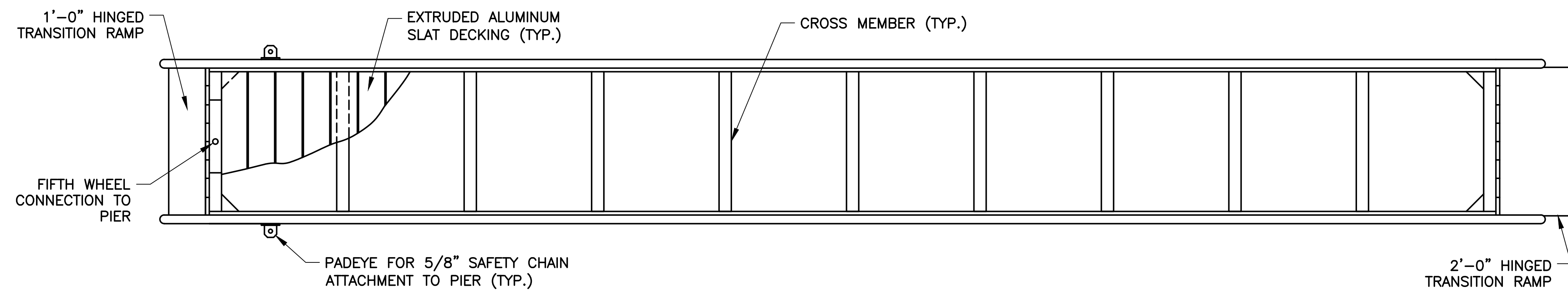

GANGWAY PLAN

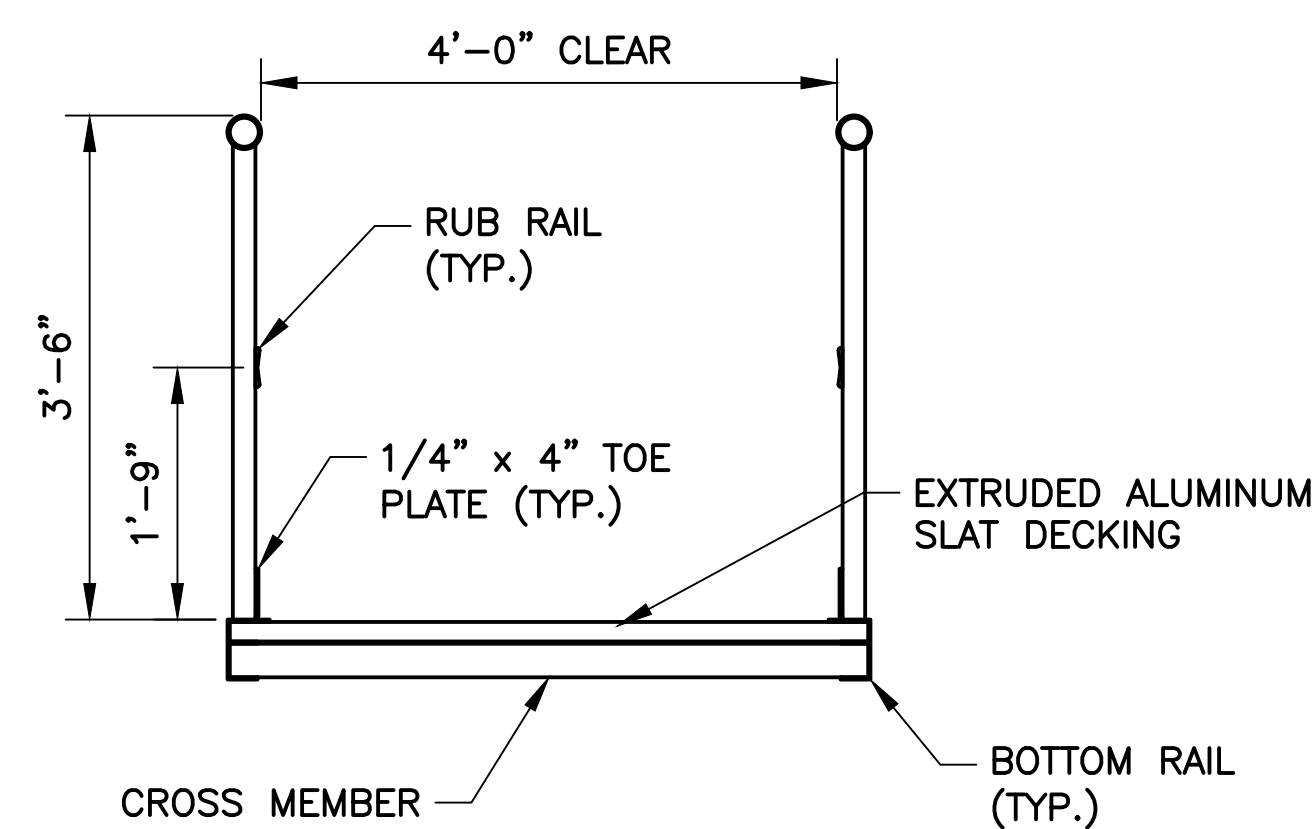

GANGWAY TYPICAL SECTION



NO.	DATE	REVISION	BY	PREPARED BY	MADE BY	ISSUED FOR CONSTRUCTION	PREPARED FOR	TITLE OF PROJECT	DRAWING TITLE	DRAWING NO.	
				BUCKMAN	B. BUCKMAN		RAZ TIROSH 517 NORTH BROADWAY UPPER NYACK, NY 10960	SEAWALL REHABILITATION AND DOCK INSTALLATION	GANGWAY DETAILS	MR-08	
					B. BUCKMAN			PROJECT LOCATION			DATE 4/1/2021
					B. BUCKMAN			517 NORTH BROADWAY UPPER NYACK, NY			REVISION NO. 0
					PROJECT NO. 19051						SHEET NO. 10 OF 12

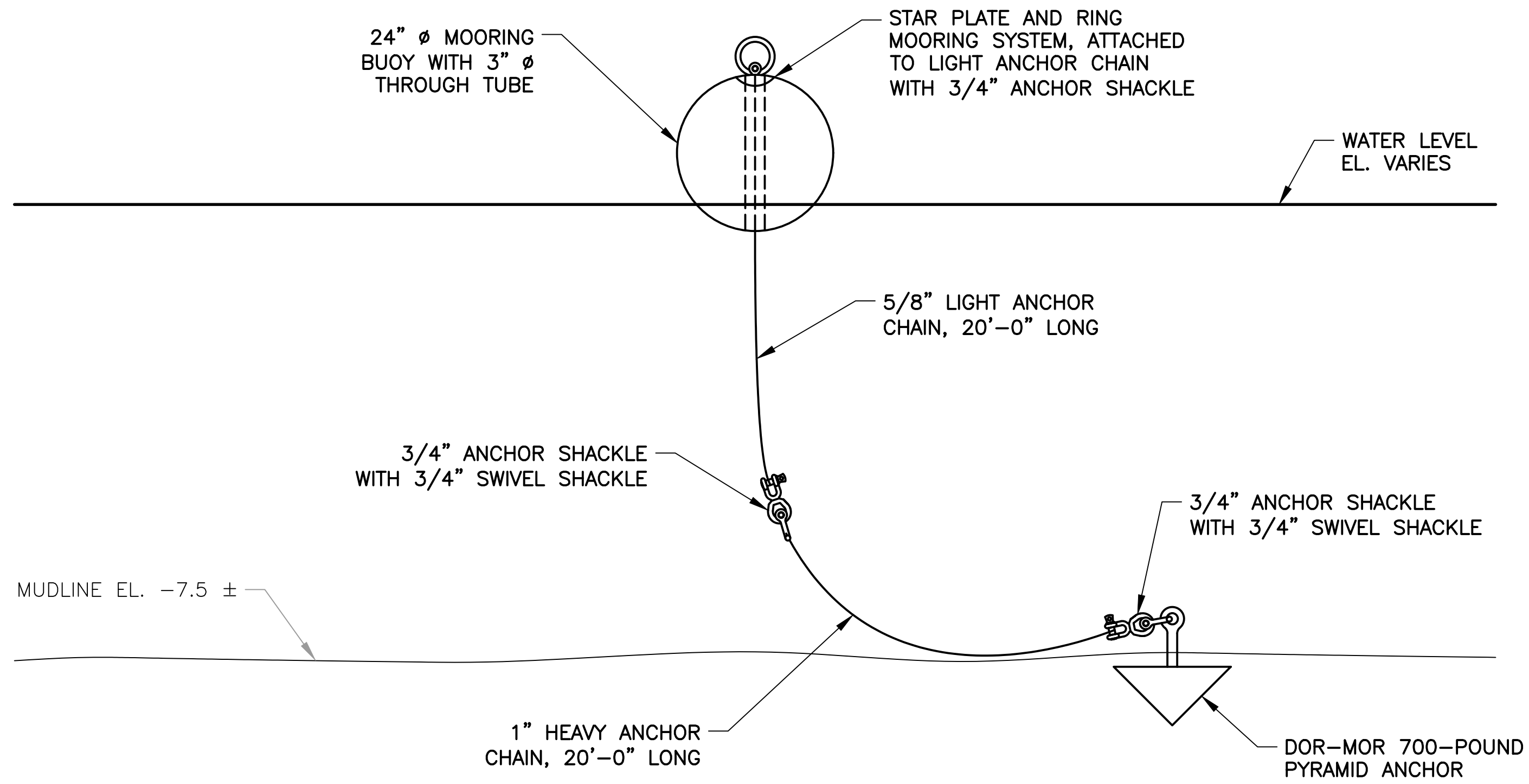

MOORING DETAIL
NO SCALE

MOORING NOTES

1. ANCHOR SHALL BE DOR-MOR PYRAMID ANCHOR OR APPROVED EQUAL. ANCHOR SHALL HAVE A HOLDING POWER OF 10 TIMES ITS WEIGHT AT A SCOPE OF 3:1.
2. LIGHT AND HEAVY ANCHOR CHAIN SHALL BE SCHEDULE 30 CHAIN OR BETTER, HOT-DIP GALVANIZED.
3. ANCHOR SHACKLES AND SWIVEL SHACKLES SHALL BE SCREW-TYPE SHACKLES, HOT-DIP GALVANIZED.
4. MOORING BUOY SHALL BE 24 INCH DIAMETER WITH A 3 INCH DIAMETER THROUGH HOLE FITTED WITH A PVC TUBE. THE BUOY SHALL HAVE A SEAMLESS, ONE-PIECE POLYETHYLENE SHELL WITH ULTRAVIOLET LIGHT INHIBITORS. THE CORE SHALL BE CLOSED CELL FOAM PROVIDING A BUOYANCY OF AT LEAST 200 POUNDS. MOORING BUOY SHALL BE MODEL 4403-T AS MANUFACTURED BY JIM BUOY OR APPROVED EQUAL.
5. STAR PLATE AND MOORING RING SHALL CONFORM TO MODEL NUMBER 4400 AS MANUFACTURED BY JIM BUOY OR APPROVED EQUAL. RING SHALL HAVE 6 INCH DIAMETER AND BE 3/4 INCH THICK. THE STAR PLATE SHALL BE 1/4 INCH THICK AND 6 INCHES IN OUTER DIAMETER. THE STAR PLATE SHALL BE CONCAVE TO FIT THE TOP OF THE MOORING BUOY. RING AND STAR PLATE SHALL BE HOT-DIP GALVANIZED.

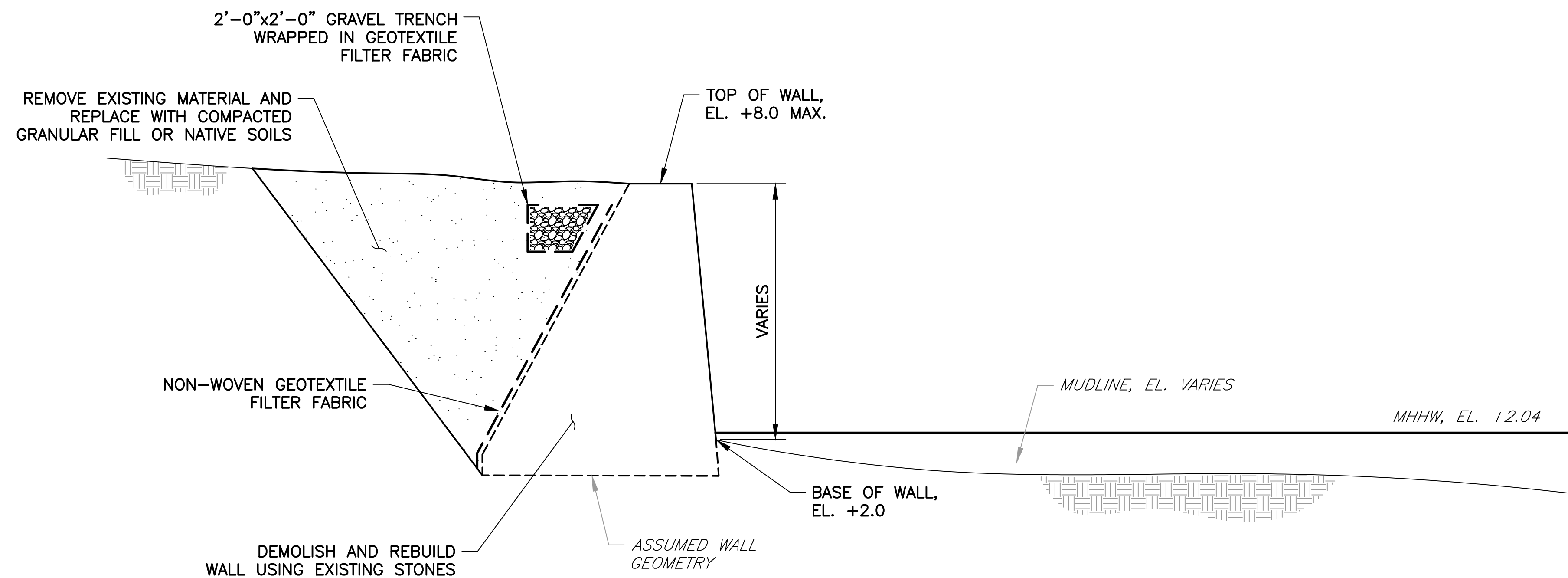

WALL RECONSTRUCTION DETAILS
NO SCALE

SEAWALL NOTES

1. ALL ELEVATIONS REFER TO THE NORTH AMERICAN VERTICAL DATUM OF 1988 (NAVD88).
2. LARGEST STONE PIECES WILL BE PLACED AT THE BOTTOM OF THE RECONSTRUCTED SEAWALL TO PREVENT WASHOUT.
3. CONTRACTOR SHALL STAGE THE WORK FROM LAND.
4. EXERCISE CARE DURING DEMOLITION, WORKING SO MATERIAL FALLS AND STAYS UPLAND, TOWARD THE SHORE.
5. WHEN REBUILDING SEAWALL, MATCH EXISTING FRONT FACE BATTER.
6. AT NORTH END OF WALL, SLOPE TOP OF WALL TO MEET TOP OF SEAWALL ON ADJACENT PROPERTY.

NO.	DATE	REVISION	BY	PREPARED BY	MADE BY	ISSUED FOR CONSTRUCTION	PREPARED FOR	TITLE OF PROJECT	DRAWING TITLE	DRAWING NO.				
1	05/26/21	ADDRESS VILLAGE COMMENTS	BDB		B. BUCKMAN		RAZ TIROSH 517 NORTH BROADWAY UPPER NYACK, NY 10960	SEAWALL REHABILITATION AND DOCK INSTALLATION PROJECT LOCATION 517 NORTH BROADWAY UPPER NYACK, NY	MISCELLANEOUS DETAILS	MR-10				
				B. BUCKMAN								DATE	4/1/2021	
				B. BUCKMAN									REVISION NO.	1
					PROJECT NO.					19051				SHEET NO.

BUCKMAN
BUCKMAN ENGINEERING, PLLC
255 DEAN STREET
BROOKLYN, NY 11217

WARNING - IT IS A VIOLATION OF SECTION 7209 OF THE STATE EDUCATION LAW FOR ANY PERSON TO ALTER THIS DRAWING IN ANY WAY UNLESS ACTING UNDER THE DIRECTION OF A LICENSED PROFESSIONAL ENGINEER. THE ALTERING ENGINEER SHALL AFFIX THEIR SEAL AND THE NOTATION "ALTERED BY" FOLLOWED BY THEIR SIGNATURE, THE DATE OF ALTERATION, AND A SPECIFIC DESCRIPTION OF THE ALTERATION.