

**CONSTRUCTION NOTES FOR FABRICATED SILT FENCE**

1. WOVEN WIRE FENCE TO BE FASTENED TO FENCE POSTS WITH WIRE TIES OR STAPLES. POSTS: STEEL EITHER 1" OR 2" TYPE OR 2" HARDWOOD. FENCE: WOVEN WIRE 14 1/2 GA. 6" MAX. MESH OPENING.
2. FILTER CLOTH TO BE FASTENED SECURELY TO WOVEN WIRE FENCE WITH TIES SPACED EVERY 24" AT TOP AND MID SECTION. FILTER CLOTH: FILTER X, MIRAFI 100X, STABILINKA 1140X, OR APPROVED EQUAL. PREFABRICATED: GEOTAB, ENVIROFENCE, UNIT: OR APPROVED EQUAL.
3. WHEN TWO SECTIONS OF FILTER CLOTH ADJOIN EACH OTHER THEY SHALL BE OVERLAPPED BY SIX INCHES AND FOLDED.
4. MAINTENANCE SHALL BE PERFORMED AS NEEDED AND MATERIAL REMOVED WHEN "BULGES" DEVELOP IN THE SILT FENCE.

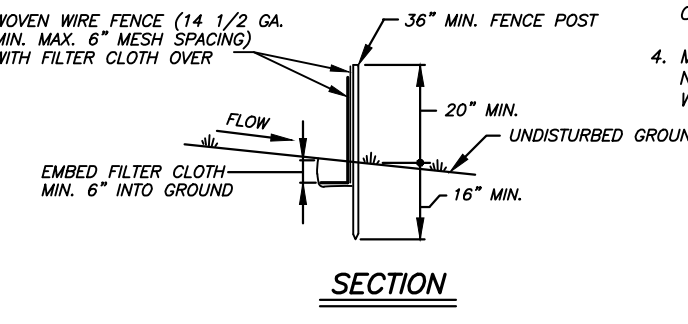

**WIRE REINFORCED SILT FENCE**

NTS

**LEGEND**

- DRAINAGE INLET W/PIPES
- DRAIN MANHOLE/ WITH PIPES
- TOP CURB @ CATCH BASIN
- TOP GRATE FIELD INLET
- REINFORCED CONCRETE PIPE
- CORRUGATED PLASTIC PIPE
- UTILITY POLE
- UTILITY POLE WITH LIGHT
- WATER VALVE
- HYDRANT
- GAS VALVE
- OVERHEAD WIRES
- GAS LINE
- GAS, ELEC, TEL, CATV
- WATER LINE
- CONTOUR LINE
- SPOT GRADE
- PROPOSED CONTOUR LINE
- PROPOSED SPOT GRADE

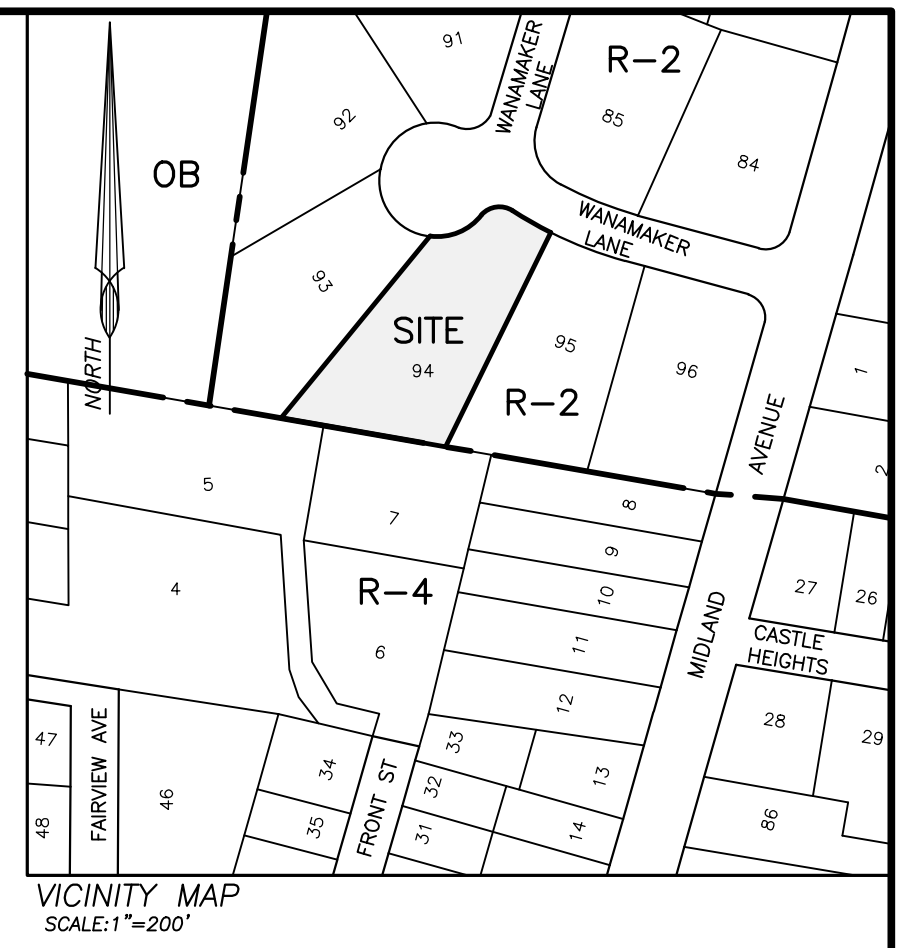

**SITE PLAN NOTES**

1. RECORD OWNER & APPLICANT: COMITO HOMES LLC, 87 SIXTH AVE, NYACK, NY 10960
2. ZONE: R-2
3. EXISTING TAX LOT 60.13-2-94
4. ALL NEW UTILITIES, INCLUDING ELECTRIC AND TELEPHONE SERVICE SHALL BE INSTALLED UNDERGROUND.
5. THIS PLAN DOES NOT CONFLICT WITH THE COUNTY OFFICIAL MAP, AND HAS BEEN APPROVED IN THE MANNER SPECIFIED BY SECTION 239-N OF THE GENERAL MUNICIPAL LAW OF THE STATE OF NEW YORK.
6. ANY EXISTING UTILITIES (POLES, HYDRANTS, ETC) AFFECTED BY THE DEVELOPMENT OF THIS PARCEL SHALL BE RELOCATED AT THE DEVELOPER'S EXPENSE PRIOR TO THE ISSUANCE OF ANY CERTIFICATE OF OCCUPANCY.
7. THE CORNERS OF THE LOTS SHALL BE MARKED WITH METAL RODS 3/4" IN DIAMETER, AND AT LEAST 30" IN LENGTH, TO BE INSTALLED AFTER FINAL GRADING PRIOR TO SEEDING.
8. ALL AREAS DISTURBED BY ON-SITE GRADING SHOULD BE LIMED AND FERTILIZED.
9. NEW HOUSE SEWER CONNECTION SHALL BE BY GRAVITY SEWER WITH A MIN. SLOPE OF 2.0%.
10. WATER SUPPLY BY SUEZ WATER NEW YORK.
11. SANITARY SEWER AND WATER SERVICE LINES SHALL BE LAID IN SEPARATE TRENCHES WITH A MINIMUM HORIZONTAL SEPARATION OF TEN FEET.
12. SUBJECT TO VILLAGE AND STATE CONSTRUCTION AND UTILITY STANDARDS, AS APPLICABLE.
13. THE DEVELOPER SHALL CONFORM TO THE "NEW YORK STATE GUIDELINES FOR URBAN EROSION AND SEDIMENT CONTROL".
14. A COVENANT SHALL BE FILED IN THE ROCKLAND COUNTY CLERK'S OFFICE (TO THE SATISFACTION OF THE VILLAGE ATTORNEY) BINDING THE HOMEOWNERS TO MAINTENANCE OF THE STORMWATER FACILITIES ON THE LOT.
15. PROTECTION OF TREES: NO MATERIAL OR TEMPORARY SOIL DEPOSITS SHALL BE PLACED WITHIN THE DRIP LINE OF ANY EXISTING TREE TO BE PRESERVED, EXCEPT WHERE ENGAGED FOR TREE REMOVAL. NO EQUIPMENT SHALL BE OPERATED WITHIN 50% OF CRITICAL ROOT RADIUS OF ANY TREE TO BE PROTECTED IN THIS ORDINANCE NOR SHALL EQUIPMENT BE OPERATED AT ANY TIME IN SUCH MANNER AS TO BREAK, TEAR, BRUISE, DECORTICATE OR OTHERWISE INJURE ANY LIVING OR DORMANT TREE.
16. EXISTING TREES SHOWN ON THE GRADING PLAN AS TO REMAIN, ARE TO REMAIN UNDISTURBED AND BE PROTECTED WITH A 6 FOOT HIGH WOODEN FENCE WITH POSTS PLACED AT THE DRIP LINE OF THE BRANCHES OR AT 8 FT. MINIMUM FROM THE TREE TRUNK. ANY EXISTING TREE SHOWN TO REMAIN THAT IS REMOVED DURING CONSTRUCTION SHALL BE REPLACED BY A 4" CALIPER HARDWOOD SHADE TREE AS DIRECTED BY THE LANDSCAPE ARCHITECT. WHEN AN AREA OF EXISTING TREES IS SHOWN TO BE SAVED, AND AN AREA OF SUCH TREES HAS BEEN REMOVED, A 2 1/2"-3" CALIPER HARDWOOD SHADE TREE SHALL BE PLACED FOR EVERY 200 SF OF AREA DISTURBED.
17. ALL TREES SCHEDULED FOR REMOVAL MUST HAVE A VALID VILLAGE OF UPPER NYACK TREE PERMIT PRIOR TO CUTTING OR REMOVAL.
18. DATUM: NAVD '88
19. RETAINING WALL(S) SHALL BE DESIGNED BY A NEW YORK STATE LICENSED PROFESSIONAL ENGINEER AND SUBMITTED TO THE VILLAGE FOR REVIEW AT THE TIME OF APPLICATION FOR A BUILDING PERMIT. A LETTER FROM THE NYS PROFESSIONAL ENGINEER CERTIFYING CONSTRUCTION WITH ACCORDANCE WITH DESIGN SHALL BE PROVIDED PRIOR TO CERTIFICATE OF OCCUPANCY.
20. SITE PLAN SHALL BE VALID FOR A PERIOD OF THREE YEARS FROM THE DATE OF APPROVAL, WITHIN WHICH TIME APPLICANT SHALL SECURE A BUILDING PERMIT.
21. PLANNING BOARD AND ARCHITECTURAL BOARD APPROVAL FOR SITE AND HOUSE PLANS IS REQUIRED PRIOR TO THE ISSUANCE OF A BUILDING PERMIT.
22. IN ACCORDANCE WITH SECTION 6.6 OF THE UPPER NYACK ZONING CODE, SINCE THE "WINFIELD HOMES", SUBDIVISION WAS APPROVED PRIOR TO THE ADOPTION OF THE "SLOPE FORMULA", THE LOT IS GRANDFATHERED AND THE SLOPE AREA RESTRICTIONS DO NOT APPLY.
23. PROVIDE PLANTINGS TO SCREEN RETAINING WALL AT EAST PROPERTY LINE - SEE LANDSCAPING PLAN.
24. VERIFY INFILTRATION RATE AT TIME OF CONSTRUCTION AND AMEND THE DRYWELL DESIGN IF/AS NEEDED.

**BULK TABLE • ZONE R-2 • ONE FAMILY RESIDENCE**

ITEM	REQUIRED	PROPOSED
MINIMUM LOT AREA	30,000 SF	34,777 SF
MINIMUM FRONT FOOTAGE ON STREET	100 FT	142.61'
MINIMUM SETBACK FROM FRONT STREET LINE	35 FT	43'±
MINIMUM SETBACK FROM SIDE AND REAR LOT LINES	SIDE - 25 FT REAR - 25 FT	25.2'/33.0' 109'+
MAXIMUM COVERAGE OF LOT BY BUILDINGS & STRUCTURES	20%	12%
MAXIMUM COVERAGE OF LOT BY PRIMARY BUILDING	12%	9%
MAXIMUM STRUCTURE HEIGHT	35'	34.6' PER ARCH
MINIMUM LIVABLE FLOOR AREA SINGLE FLOOR DWELLINGS	1250 SQ FT	NA
MINIMUM LIVABLE FLOOR AREA TWO (2) FLOOR DWELLINGS	FIRST FLOOR: 800 SQ FT SECOND FLOOR: 750 SQ FT	>800 SF >750 SF

**LEGEND FOR EROSION CONTROL DURING CONSTRUCTION**

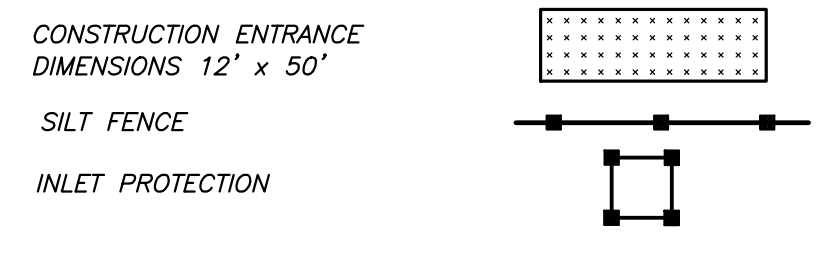

IMPERVIOUS BREAKDOWN  
EXIST IMPERVIOUS AREA= 0 SF  
PROP IMPERVIOUS AREA=4,280 SF  
ADDITIONAL GAR AND DRWY:700 SF

- REFERENCES:**
1. BEING LOT 3 ON A MAP ENTITLED "WINFIELD HOMES", FILED IN THE ROCKLAND COUNTY CLERK'S OFFICE AS MAP 6021.
  2. DEEDS ON FILE IN THE ROCKLAND COUNTY CLERK'S OFFICE AS FOLLOWS: LIBER282 PAGE 2118, INST# 2000-36572, INST# 2003-5167

		<b>SITE PLAN FOR ATTACHED GARAGE</b>	TAX LOT # 60.13-2-94
		<b>COMITO - WANAMAKER LA.</b>	AREA 34,777 SF
		VILLAGE OF UPPER NYACK, TOWN OF CLARKSTOWN ROCKLAND COUNTY, STATE OF NEW YORK	FILE 21847 SITE GARAGE
		<b>JAY A. GREENWELL, PLS, LLC</b>	SCALE 1"= 20'
		SURVEYING - LAND PLANNING 85 LAFAYETTE AVENUE, SUFFERN, NEW YORK, 10901 PHONE 845-357-0830 FAX 845-357-0756	DATE 12-8-18
		JAY A. GREENWELL, PLS NYS LIC. # 49676	JOB NO. 21847